

The 1550 nm Forward Transmitter Module - Standard series (FT5S) is designed to plug into PBN's latest generation Advanced Intelligent Multi-services Access platform - the AIMA3000.

PBN's AIMA3000 FT5S is available in single, dual laser configurations. It features advanced forward transmitters engineered for multi-service operators (MSOs) to increase network capacity to satisfy an ever-growing subscriber demand for more bandwidth. The module's operating wavelength conforms to ITU's standards and works with PBN's Erbium Doped Fiber Amplifier Module (EDFA). It allows for full-spectrum broadcast and narrowcast channels, providing the utmost flexibility for MSOs during the transition to all digital.

The FT5S series employs an advanced RF circuit design and laser with high-quality and low-chirp characteristics. The module offers a consistent optical modulation index (OMI) and ensures high-index optical power output. In addition, it is a cutting-edge optoelectronic design for the delivery of high-quality transmissions, in both analog and digital formats over passive fiber optical networks.

All FT5S models can also be conveniently monitored and controlled through a computer connected to one of the Ethernet ports via the ASMM module. All module settings are retained in non-volatile memory

to ensure trouble-free operation. Bulk updating, automatic uploading and downloading of configuration files can be done when using PBN's NMSE web-based management system.



Key Features and Functions

- Plug-and-play with the AIMA3000 platform
- High quality 1550 nm, isolated low-chirp analog DFB laser
- RF amplifier gain blocks with advanced GaAs technology for better performance
- Conforms to the ITU DWDM standards
- Frequency response from 45 MHz to 1218 MHz fit for both broadcast and narrowcast applications
- Alarm monitoring via ASMM web interface and PBN NMSE
- Automatic gain control (AGC) for a consistent optical modulation index (OMI)
- Automatic thermo-cooler control (ATC) for a consistent laser temperature
- Automatic power control (APC) for a consistent optical output power
- Available in single, dual transmitter configurations
- Up to 64 transmitters per chassis
- Remote firmware upgrade and auto upload/download of configuration files through ASMM web interface or using PBN's NMSE
- Fully FCC, CE, and RCM compliant

Block Diagram

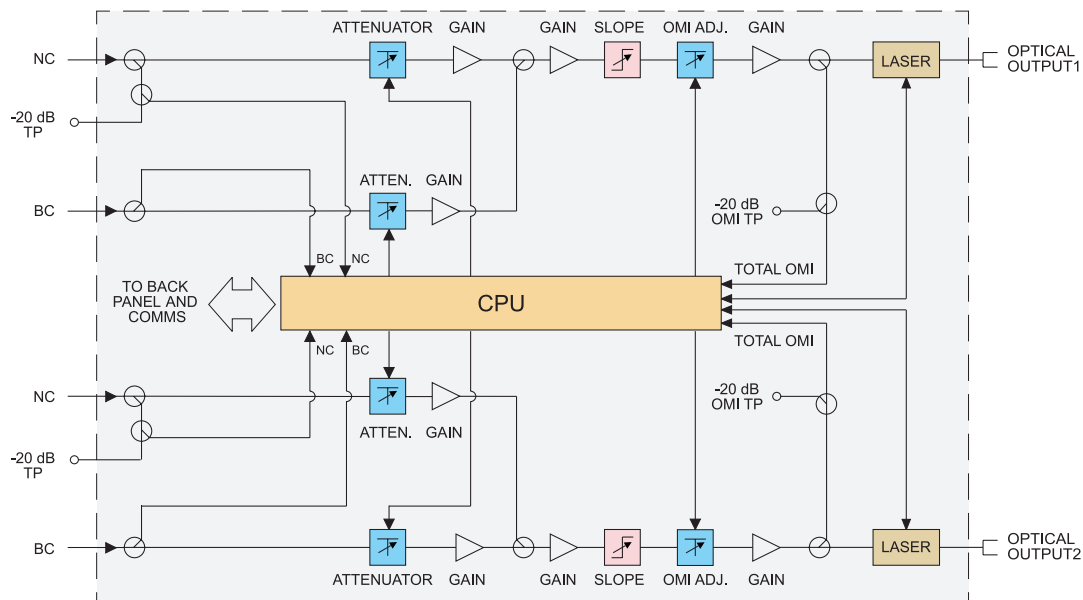

Specifications

Optical Performance

Optical wavelength	1550 nm ±5 nm or ITU wavelength
Optical outputs	1 or 2
Output power	8 dBm, 9 dBm, 10 dBm
Optical connector	SC/APC ⁽¹⁾ , FC/APC, LC/APC, E2000/APC
Laser RIN	< -155 dB/Hz

RF Performance

RF bandwidth	45 MHz to 1218 MHz
RF flatness	± 0.75 dB
RF input return loss	> 16 dB
RF input level, NC nominal ⁽²⁾	25~35 dBmV per channel
RF input level, BC nominal ⁽²⁾	15~25 dBmV per channel
AGC range	± 3 dB
Isolation of NC and BC	> 50 dB
RF impedance	75 Ω
RF test point relative to RF input port	-20 dB ± 1 dB
Isolation between transmitters	45~1000 MHz: > 65 dB 1001~1218 MHz: > 60 dB
RF input connectors	Single port: 2 x GSK-type female (1 for NC , 1 for BC) Dual port: 4 x GSK-type female (2 for NC , 2 for BC)
RF test points	Single port: 3 x Mini-SMB ⁽³⁾ Dual port: 4 x Mini-SMB ⁽⁴⁾
Alarms and laser status	Front-panel LEDs, SNMP Traps

Link Performance⁽⁵⁾

CNR (4 MHz NBW)	> 53 dB
CSO	> 58 dB
CTB	> 67 dB
MER	> 38 dB
BER	< 1E-9

General

Power supply	Powered via AIMA3000 backplane
Power consumption	Single port: < 8.0 W Dual port: < 15.0 W
Operating temperature	-5 °C to +55 °C
Storage temperature	-25°C to +70 °C
Dimensions (WxDxH)	24.6 x 410 x 152.5 mm
Weight	0.88 kg
Supported network management options	PBN's NMSE or through ASMM's Web Interface

Note :

(1) Standard option. Contact a PBN Sales Representative for availability of other options.

(2) dBuV=60+dBmV.

(3) Three mini-SMBs on front panel: one each for BC and NC inputs and one to measure RF input before the laser transmitter.

(4) Four mini-SMB connectors on front panel: Two NC inputs test ports and two to measure RF input before the laser transmitter.

(5) CNR, CSO, CTB and MER are loaded with 30 NTSC+124 QAM256 or 30 PAL D/K+85 QAM256. BER is loaded with 30 NTSC+124 QAM256, 30 PAL D/K+85 QAM256 or 153 QAM256. All are measured with PBN referenced optical receiver with 5 km single-mode optical fiber 0 dBm.

Order Details

A-FT5S-[V]-[W]-[X1X2]-[Y]-[Z] | 1550 nm Forward Transmitter - Standard

Options:

V	Number of Optical Ports	Y	Optical Connector Type
S	Single (1)	S	SC/APC ⁽³⁾
D	Dual (2)	F	FC/APC
W	Optical Output Power	L	LC/APC
08	8 dBm (6.3 mW) optical power	E	E2000/APC
09	9 dBm (8 mW) optical power	Z	Bandwidth
10	10 dBm (10 mW) optical power	1G	45 ~ 1000 MHz
X1X2^{(1) (2)}	First Channel Last Channel	12	45 ~ 1218 MHz
21	192.1 THz (1560.61 nm)		
23	192.3 THz (1558.98 nm)		
25	192.5 THz (1557.36 nm)		
27	192.7 THz (1555.75 nm)		
29	192.9 THz (1554.13 nm)		
31	193.1 THz (1552.52 nm)		
33	193.3 THz (1550.92 nm)		
35	193.5 THz (1549.32 nm)		
⋮	⋮		
51	195.1 THz (1536.61 nm)		

Note:

(1) Default spacing is 200 GHz. For other wavelength configurations not listed, please contact PBN.

(2) X2 used only in dual transmitter versions

• Dual version, X1 is first channel and X2 is second channel

The third channel is 200 GHz higher from the second.

Examples:

Single	X1	25
Dual	X1X2	2527, 2525

Contact PBN Representatives for detailed optical channel information.

(3) Standard option. Contact a PBN Sales Representative for availability of other options.