

The PBN AIMA3000 RRAS series Analog Return Receiver - Standard is designed for multi-services operators to increase network-return capacities for the ever-growing demand for bandwidth, while minimizing physical headend space and power usage.

With the optional embedded Full Band Capture (FBC) module, it enables the operator to capture and monitor the return path spectrum helping the operator to quickly find and locate the upstream noise and the related upstream signal levels. Advanced spectrum analyzing software is available as in a standalone version or as module within PBN's NMSE Software suite. It also can be easily integrated into operators exist network management system.

Next to above mentioned online management and controlling capabilities the can also be conveniently monitored and controlled through a computer directly connected to one of the Ethernet ports of the ASMM module.

All module settings are retained in non-volatile memory to ensure trouble-free operation. Bulk updating, automatic uploading and downloading of configuration files is possible using PBN's NMSE web-based management system.

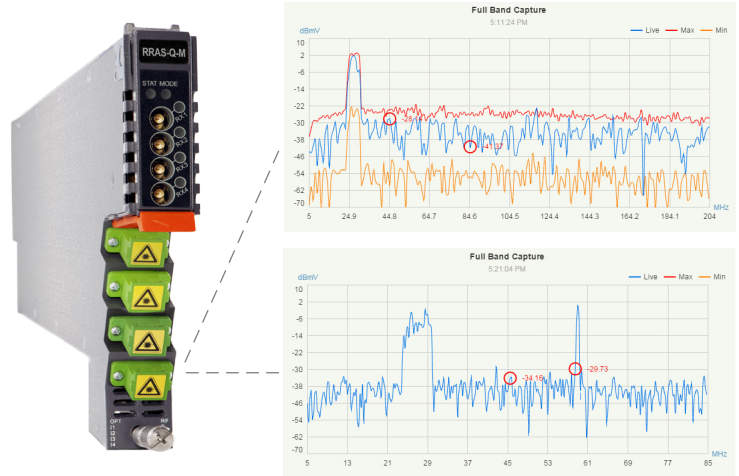

Key Features and Functions

- Bandwidth 5 ~ 204 MHz to meet EuroDOCSIS and DOCSIS 3.0/3.1 frequency band requirements
- RF output 48 dBmV at -6 dBm optical input and OMI of 6%
- Wide band receiver (1260~1620nm) to suit CWDM and DWDM applications
- Allows up to 64 receivers (4x16 Modules) in only 4 RU of space
- User-selectable MGC or AGC
- Easy to install due to RF-Paddle board backplane design
- Plug-and-play and hot-swappable
- Dedicated testport per return channel
- Fully FCC, CE, and RCM compliant
- Real-time alarm monitoring
- Full Band Capture offers automated and 7*24 return path/upstream RF and data performance monitoring and analysis
- Help operators preemptively identify and address spectrum variances
- Lower capital expenses by eliminating the need for expensive test equipment
- Web-browser access eliminates the need for a thick client and a mobile APP is available
- An intuitive user interface similar as meter adapt to user's operating habits
- Improve network maintenance efficiency and Increase customer satisfaction
- FBC software which can work independently, in PBN NMSE or be integrated into third-party systems

Block Diagram

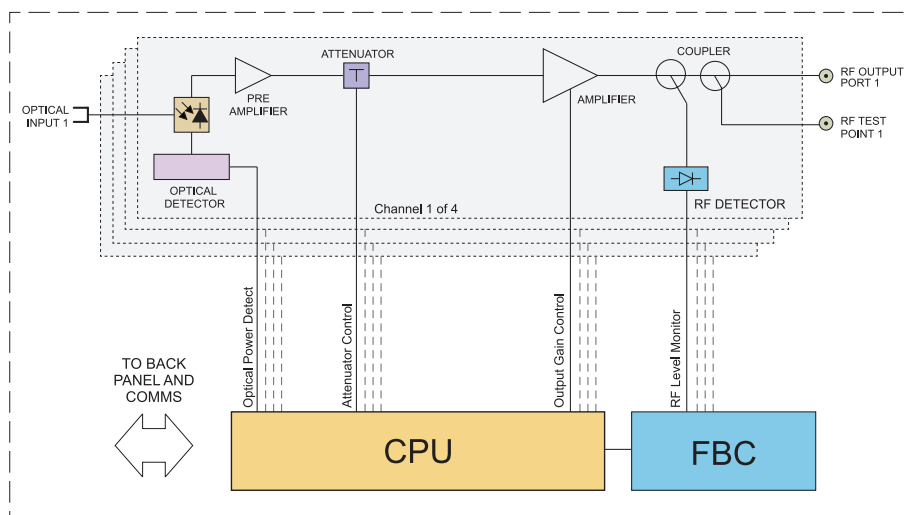

Specifications

Optical Performance

Optical wavelength	1260 nm to 1620 nm
Optical inputs	-18 dBm to +2 dBm
Optical return loss	> 50 dB
Optical connectors	4 x SC/APC ⁽¹⁾ , FC/APC, LC/APC, E2000/APC

RF Performance

RF bandwidth	5 MHz to 204 MHz
RF output level ⁽²⁾	34 dBmV
RF flatness	± 0.75 dB (5 MHz to 204 MHz)
Gain adjustment	up to 45 dB in 0.5 dB increments (default 35 dB)
RF impedance	75 Ω
RF return loss	> 18 dB
Receiver isolation	> 65 dB
RF test point relative to RF output port	-20 dB ± 1 dB
RF connectors	4 x GSK-type female
RF test points	4 x Mini-SMB
Alarms and status	Front-panel LEDs, SNMP Traps

Link Performance

CNR ⁽³⁾	> 52 dB
IMD2 ⁽⁴⁾	> 61dB
NPR ⁽⁵⁾	> 35 dB (over dynamic range of 15 dB)

General

Power supply	Powered via AIMA3000 backplane
Power consumption	< 24 W
Operating temperature	-5 °C to +55 °C
Storage temperature	-25 °C to +70 °C
Dimensions (WxDxH)	24.6 x 410 x 152.5 mm
Weight	0.95 kg
Supported network management options	PBN's NMSE or through ASMM's Web Interface

With the FBC module

Frequency Capture Range	5 to 204 MHz
Dynamic range	60 dB
Spectrum Lines	3, including live, max hold and min hold
RBW	Up from 30KHz
VBW	Auto adaptable
Vertical Markers	2

Note:

- (1) Standard option. Contact a PBN Sales Representative for availability of other options.
- (2) Measured in a typical system with -13 dBm optical input, 6% OMI, gain setting adjusted to maximum (the stated RF output level does not necessarily apply with other optical input levels). dBuV= 60+dBmV.
- (3) Measured @ -2 dBm, 6% OMI, 4 channels
- (4) RRAS: Measured in a typical system with PBN ODN4P-RT, 4 channels, (11.5 MHz, 26.5 MHz, 45.5 MHz and 58.5 MHz), 0 dBm, 6% OMI. IMD2 is measured at f1 ± f2.
- (5) RRAS: Measured in a typical system with PBN ODN4P-RT, 10 km single mode optical fiber using 35 MHz noise loading.

Order Details

A-RRAS-[W]-[X]-[Y]-[Z] Analog Return Receiver - Standard

Options:

W	Optical Ports	Z	Bandwidth
	Q Quad (4)	20	5 ~ 204 MHz (Standard)
X	FBC function ⁽¹⁾		
	M With FBC Management		<i>Note:</i>
Y	Optical Connector Type		(1) Option for FBC Management configurations only, if not used omit X when making an order.
	S SC/APC ⁽²⁾		(2) Standard option. Contact a PBN Sales Representative for availability of other options.
	E E2000/APC		
	F FC/APC		
	L LC/APC		