

# BOOSTRAL 751

Optical FTTB micronode, 1 active output, 1.2 GHz / 200 MHz

## FORWARD PARAMETERS

Wavelength	1545 - 1555 nm 1540 - 1565 nm on request
Bandwidth	85...258 - 1218 MHz
Optical AGC range	- 6 - 0 dBm
Flatness <sup>1</sup>	± 1.0 dB
Equivalent Input Noise Current	6 pA / √Hz
Output level: <sup>2</sup>	
CTB ≤ - 58 dBc	112 dBμV
CSO ≤ - 59 dBc	112 dBμV
Digital Output level <sup>3</sup>	
CINR = 41.5 dB	103 dBμV
Gain limited output level <sup>4</sup>	113 dBμV

## RETURN PARAMETERS

Number of wavelengths	up to 8
Number of channels per wavelength	up to 4
Frequency range	5 - 65...204 MHz
Flatness <sup>5</sup>	± 1.0 dB
Optical output power	
ON	2,5 dBm -0.5/+1,5 dB
OFF	< -30 dBm
RF input threshold <sup>6</sup>	70 ± 2 dBμV
Min RF input level to get 10% OMI <sup>6</sup>	75 dBμV
NPR / Dynamic range <sup>7</sup>	40 dB / 5 dB

## OTHERS

Return loss <sup>8</sup>	≥ 18 dB
Directional testpoints FWD / REV	- 20 ± 0.75 dB / 0 ± 0.75 dB
Voltage range:	
remote powering	30 - 65 V AC
mains powering	230 ± 10% V AC
Max. Current for RF / AC IN ports	0 / 0,75 A
Power consumption	< 14 W
Operation temperature range <sup>9</sup>	- 40 - 65 °C
Optical connectors	SC / APC
RF Connectors	1 x F female
Protection class	IP 42
Dimensions (W x L x H)	218 x 204 x 87 mm
Weight	1.5 kg

## AVAILABLE VERSIONS

BOOSTRAL 751 259M O	mains powering, one fiber
BOOSTRAL 751 259Y O	remote powering, one fiber



**1.2 GHz technology**  
An extended bandwidth in downstream up to 1.2 GHz; DOCSIS 3.1 standard compliant



**200 MHz technology**  
A possibility of extending bandwidth in upstream up to 200 MHz



**RFoG MDU / FTTB**  
To be used in a modern RFoG MDU / Fiber To The Building architecture



**BURST mode**  
A laser lifetime significantly extended; noise reduction; reduced energy consumption



**OBI FREE SYSTEM**  
Device designed to work in OBI FREE system



**VIG (VECTOR INGRESS GUARD)**  
System compliant; Verification and elimination of the source of ingress in the network



**xPON port (on request)**  
A flexible solution to be used in the scenarios combined with xPON networks



**Dense CWDM**  
Up to 32 devices per one fiber. Decreased CAPEX, maintenance and logistic costs.

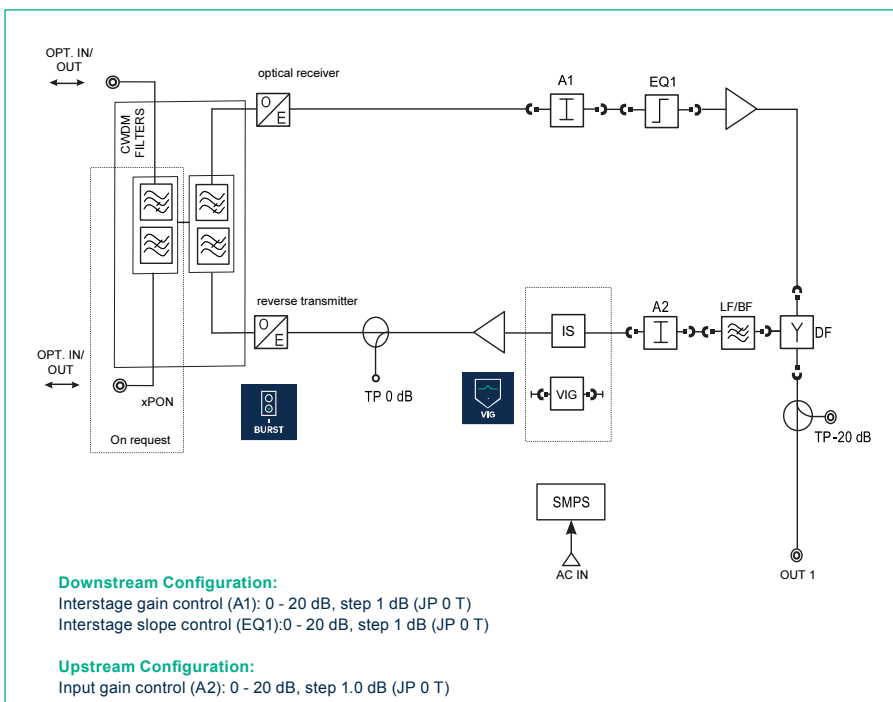

- In a range 85 - 862 MHz; ± 1.5 dB up to 1218 MHz; typical value
- According to EN 50083-3; 12 dB slope between 85 - 862 MHz; 42 channels CENELEC; typical value
- Full digital load 258 - 1218 MHz, 120 channels QAM 256, 12 dB slope
- AGC ON; 3.5% OMI; -6 dBm optical input level; 1550 nm; typical value
- Up to 204 MHz; typical value
- With attenuation A2 = 5 dB
- Measured with 12 dB link (15 km fiber + loss), 60 MHz BW noise load, EINC 7pA / √Hz
- In 5 - 65 MHz; 18 dB for f < 40 MHz; 18 dB - 1.5 dB / oct for f > 40 MHz, but > 11 dB
- Parameters are guaranteed in typical temperature range -20 - 55 °C

Unless otherwise specified, the whole specifications are tested with 65 / 85 duplex filters installed; at room temperature 25°C and present typical values.

18/03/2016 Specifications are subject to change without notice.