

Fiber Optic Products

MONITORING LINE SYSTEM



Main Features :

- Flexible monitoring system based on continuous monitoring of power levels with the immediate detection of signal power changes in monitored networks.
- Transmissing and OTDR automaticaly switched measurements resulting in one powerful supervising system.
- Sophisticated software for central remote supervision and archiving of obtained transmission data included.

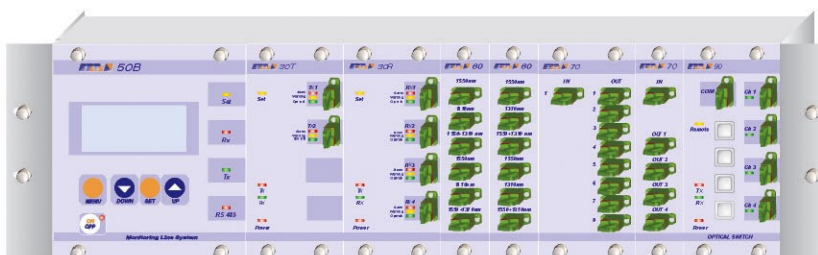

Applications:

TM Monitoring:

- Continuous measurement of optical lines by direct method and monitoring of attenuation on operated or free optical fibres of the cable.
- Direct signalling of sudden power changes and breakdowns as well as gradual deteriorating of transmission parameters.

Combined TM/OTDR Monitoring: ARFTS - Advanced Remote Fibre Test System

- Continuous measurement with automatic switching into OTDR monitoring for quick fault position localization.
- Compatible with OTDR Exfo FTB400 series.

Characteristics:

- Gradual long-term very precise measurement of stability of optical power levels on optical fibres in the whole operational temperature range.
- Fast detection of changes in optical power levels and detection of breakdowns with possibility of their signalling and position localization.
- Modular structure containing all types of sub assemblies (radiation transmitters, receivers, communicators, optical couplers and WDM modules) in different variations and configurations, that make possible to optimise MLS system for a wide spectrum of usage.
- Possibility of monitoring the operational or free fibres in loop or terminal configuration.
- Communication interface RS 485 and Ethernet (LAN) TCP/IP protocols.
- Central remote control with entire data saving and archiving with standard software, or custom based upon customers request.

BENEFITS OF HAVING THE MLS :

- Can save the user of leased fiber networks money in claiming downtimes.
- Administration of the software can be done through a web interface.
- The MLS can send a warning via e-mail and/or SMS messages.
- Fast and efficient detection of a problem in the network.
- Localisation of short-time and temporary changes in optical routes.

MLS series :

MLS 30A Complex autonomous T/R units
Combined LD optical power source (transmitter) and InGaAs PIN power meter (receiver), displayed and fully equipped unit

MLS 30T Transmitter units - LD optical power source unit, 1550, 1625 or 1310 nm

MLS 30R Receiver units - InGaAs PIN power meter units

MLS 40 Power supply units

MLS 50 COM (Control and Communication)

MLS 60 WDM units

MLS 70 Splitter units; Circulators

MLS 80 Chassis

MLS 90 Switching units

MLS 400 OTDR units (Exfo FTB400 series)

MLS software solution :

MLS soft BASIC

MLS soft MONITOR

MLS soft TRANS

MLS soft OTDR Stand Alone

MLS soft RFTS

MLS soft OTDR RFTS

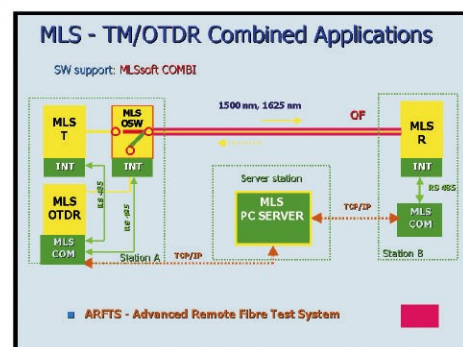

Fiber Optic Products

MONITORING LINE SYSTEM

Combined transmitter/receiver units



Combined transmitter/receiver units



Series: *MLS 30A*

MLS 30A

Brief characteristics :

- Combined T/R unit with a transmitter and a receiver in one module with full controlling and signalling localequipment;
- Front panel display and press-button keyboard, panel signalling;
- Remote or on-site control of T/R parts via the RS 485 interface;
- All MLS 50 variants compatible;
- Subsidiary voltage output: 5 V DC/300mA;
- Two independently adjustable signalling evels (warning, alarm) for each channel, pane signalling;
- Local alarm signalling with possibility of external signalling attachment (relay output);
- 1 laser diode optionally provided with the 1x2 splitter
- 1 or 2 input channels;
- Housing: 4-wide, long LGX module.

Part T transmitter :

- Laser diode optical source with increased, actively controlled power stabilisation, intended for long term stand-alone operation in remote or local station, full direct performance control, CWoperation mode, wavelength optionally in 1310 nm, 1550 nm or 1625 nm wavebands;
- Elimination of line back reflection influence on the LD operation LD stability independent on back reflection and interference changes in the line under monitoring.

Part R receiver :

- High precision, fully remote controlled optical power meter (dBm, dB) with quick time response, equipped with an internal operating memory and active stabilisation, intended for long term stand-alone operation in a remote or local station, wavelength range: from 1100 to 1650 nm;
- As a photo detector utilized InGaAs PIN diode.

Series: **MLS 30A**

MLS 30A

MLS optical transmitter units parameters

MLS unit		MLS30-Ax-1N1-A1	MLS30-Ax-1S2-A1	MLS30-Ax-1N1-D1	MLS30-Ax-1S2-D1
Part T - transmitter					
LD type		Fabry-Perot 1310 +/- 20nm Fabry-Perot 1550 +/- 20nm DFB 1615, 1625 +/- 5nm DFB 1270, 1290, ..., 1610 +/- 3 nm (CWDM Series)			
Fiber // connector type	μm	SM, 9/125 // E2000/APC			
Output optical level	dBm	> 0	> -3	> 0	> -3
CW output level stability					
24 hrs. constant temperature	dB	±0,01			
operating temperature range	dB	±0,1			
Part R - receiver					
PIN type		InGaAs			
Number of PIN diodes		1	2	1	2
Wavelength range	nm	1100 - 1650			
Input level range	dBm	from -60 to 0			
Resolution	dB	0,01			
Linearity					
for input level range of ±2,5dB	dB	±0,05			
whole input level range	dB	±0,30			
Stability					
operating temperature range	dB	±0,1			
Response					
change 0,1dB in whole range	ms	300			
Common parameters					
Operating temperature range	°C	from 0 to 40			
Subsidiary voltage output	V/mA	5/300	5/300	5/300	5/300
Power supply					
nominal voltage	V	230 (AC)	230 (AC)	48 (DC)	48 (DC)
voltage range	V			36 - 72 (DC)	36 - 72 (DC)
Maximum consumption I _{max} .	mA	85	85	350	350
Typical consumption I _{typ} .	mA	55	55	140	140
Box dimensions (w x h x d)	mm	117 x 102 x 200			

M L S 3 0 - A x - r s t - n

laser wave length
x=2 ... band 1550 nm
x=3 ... band 1625 nm
x=4 ... band 1610 nm

number of lasers
r=1

splitter
s=N ... not applied
s=S ... splitter 50/50

number of detectors
t=1 ... 1 PIN diode inputs
t=2 ... 2 PIN diode inputs

specifies the type of power supply
n=D ... 48V DC
n=A ... 230V AC
n=N ... 5V DC

Fiber Optic Products



MONITORING LINE SYSTEM

Optical receivers



*Optical
receivers*

Series: *MLS 30R*

MLS 30R

Optical Receivers unit - InGaAs PIN optical power meter, controlled

Brief characteristics :

- High precision, fully remote controlled optical power meter (dBm, dB) with quick time response, equipped with an internal operational memory and an active stabilisation circuit intended for long term stand-alone operation in a remote or local station;
- Wavelength range: 1100 - 1650 nm;
- Internal operating memory;
- Remote or local station control via the RS 485 interface;
- Without display, the optical power level read by a local PC or by a server (via M L S 50B);
- Two independently adjustable signalling levels (warning, alarm) for each channel, panel signalling;
- All MLS 50 variants compatible;
- Power supply: 48V DC;
- Up to 4 channels;
- Housing: double-wide long module, LGX compatible.

Series: **MLS 30R**

MLS 30R

Optical receiver units - parameters

MLS unit		MLS30-Rx-1-D1	MLS30-Rx-2-D1	MLS30-Rx-t-D2
Number of PIN diodes		1	2	from 1 to 4
Wavelength range	nm	1100 - 1650		
PIN type		InGaAs		
Calibrating wavelength	nm	1310 for x=1, 1550 for x=2, 1610 for x=3		
Opt. coupling type		contact (pig-tail PIN)		contactless (E2000 + PIN)
Input opt. level range	dBm	from -60 to 0		
Resolution	dB	0,01		
Fiber	μm	SM		SM or MM
Connector		E2000/APC		
Linearity				
in range of input level +2,5 dB	dB	±0,05		
all input level range	dB	±0,30		
Stability				
operating temperature range	dB	±0,1		
Response time				
var. 0,1 dB in all time	ms	300		
Operating temperature range	°C	from 0 to +40		
Power supply				
nominal voltage	V	48 (DC)		
voltage range	V	18 - 72 (DC)		
Maximum consumption I _{max} .	mA	35 for y=2 200 for y=1	35 for y=2 200 for y=1	35
Typical consumption I _{typ} .	mA	25 for y=2 60 for y=1	25 for y=2 70 for y=1	25
Box dimensions (w x h x d)	mm	59 x 102 x 200		

M L S 3 0 - R x - t - n y

wave length
used for calibration
x=1 ... band 1310 nm
x=2 ... band 1550 nm
x=3 ... band 1610 nm

number of detectors
t=1... 4

specifies the type of power supply
n=D ... DC 48V

type of the optical connection
y=1 ... SM fiber, E2000 / APC
y=2 ... built-in detector (E2000 receptacle)

Fiber Optic Products



MONITORING LINE SYSTEM

Optical transmitters



Optical transmitters

Series: *MLS 30T*

MLS 30T

Optical transmitter unit - LD optical source, controlled



Brief characteristics :

- Optical source with increased, actively controlled power stabilisation, intended for long term stand-alone operation in a remote or local station with an ability of being under full direct performance control;
- Laser diode operating in CW mode, optionally in 1310 nm, 1550 nm or 1625 nm wavebands;
- Wavelength of DFB lasers optional in range from the 1270 to the 1625 nm wavebands;
- 1 laser diode optionally provided with 1x2 or 1x4 splitter.
- Elimination of back reflections influence on the LD operation LD stability independent on back reflection and interference changes in the line under monitoring;
- Remote or local station control via RS 485 interface;
- Without display, optical power level controlled by local PC or by server (via MLS 50B);
- All MLS 50 variants compatible;
- Power supply: 48V DC;
- Housing: double - wide long module, LGX compatible.

Series: **MLS 30T**

MLS 30T

MLS optical transmitter units parameters

MLS unit (3 examples)		MLS30-Tx-D F1310-D1610-50	MLS30-Tx-D F1550-25-25-25	MLS30-Tx-D D1550-10
LD type	-	Fabry-Perot, DFB	Fabry-Perot	DFB
Wavelength	nm	1310 +/- 20 1610 +/- 5	1550 +/- 20	1550 +/- 5
Fiber // connector type	µm	SM, 9/125 // E2000/APC		
Optical output level	dBm	> 0 and > -3 (2x)	> -6 (4x)	> -0,5 and > -10
Number of optical ports		3	4	2
Number of splitters		1	1	1
CW output level stability				
24 hrs, constant temperature	dB	±0,01		
operating temperature range	dB	±0,1		
Operating temperature range	°C	from 0 to +40		
Power supply				
nominal voltage	V	48 (DC)		
voltage range	V	18 - 72 (DC)		
Maximum consumption I _{max} .	mA	150		
Typical consumption I _{typ} .	mA	70		
Box dimension (w x h x d)	mm	59 x 102 x 200		

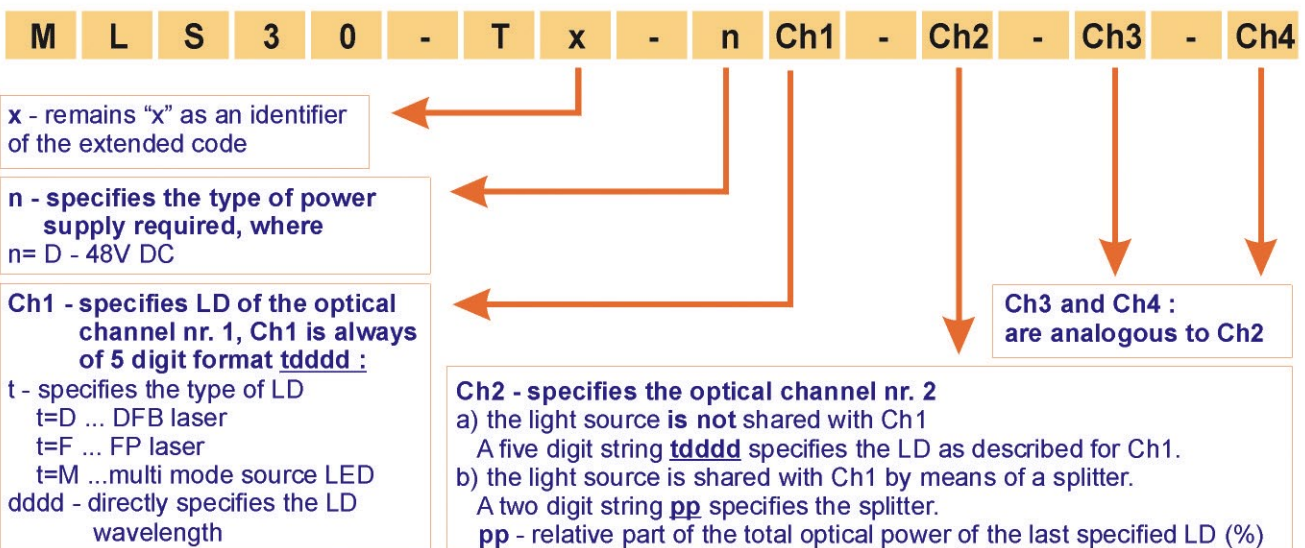

Fiber Optic Products



MONITORING LINE SYSTEM

Power supply units



Power supply units

Series: **MLS 40B**

MLS 40B

Brief characteristics :

- Switching power supply series gives you consistent, reliable, switched DC power;
- The models accept universal 100/230 VAC input voltage for worldwide use and provide multiple output terminals for easy wiring;
- Switching power supply series enables operation of the other active MLS units, transforming electric power usually from 230 VAC to 48 VDC which is designated as the MLS power distributing voltage;
- Compliant with international safety and EMI standards. (All units are of full CE compliance, EN61000-3-2 included);
- Over-current, over-voltage and over-temperature protection;
- Available RoHS compliant;
- Available with convection cooling, i.e. no internal fan;
- Housing: double - wide long module, LGX compatible.
- The units provides fully floating DC voltages suitable for other electrically powered MLS units
 - basic output DC voltage: 48V
 - supplemental standby output DC voltage: 5V
 - supplemental fan output DC voltage: 12V
- Total maximum output power is specified in the range from 40 to 150 W.

Series: **MLS 40B**

MLS 40B

Power supply units - parameters

MLS unit		MLS40-B5-A 60W	MLS40-B4-A 60W	MLS40-B7-A 150W
Input DC voltage range	V	from 120 to 300		-
Input AC voltage range	V	form 85 to 264		
Input AC frequency range	Hz	form 47 to 440		form 47 to 63
Maximum input peak surge current				
- for 115 VAC		18		-
- for 230 VAC	A	36		-
- for 264 VAC		-		40
Maximum input current (rms)	A	1,5 (for 115 VAC)		2,78 (for 120 VAC) 1,36 (for 230 VAC)
Fuse	A	T3,15 / 250 VAC		T6,3 AH / 250 VAC
Number of output connectors	-	4x MIC334		3x MIC334 1x MIC338
Output DC voltage 1	V	48		
- maximum power	W	60		150
- overload protection	-	YES		
- temperature stability	% / K	0,04		0,02
Output DC voltage 2	V	5	-	5
- maximum power	W	8	-	5
- overload protection	-	YES	-	YES
- fuse	A	1,6	-	NA
Output DC voltage 3	V	-	-	12
- maximum power	W	-	-	4
- overload protection	-	-	-	YES
Working ambient temperature	°C	from 0 to 40		
Storage temperature	°C	form -40 to 85		
Package	-	LGX 3U/2		
Built-in ventilator	-	YES		NA
Weight	kg	0,9	0,8	1,0
Box dimensions (w x h x d)	mm	59 x 102 x 200		

M L S 4 0 - a b - n w

specifies the box width
 a=A ... 4 LGX
 a=B ... 2 LGX
 a=C ... 1 LGX

specifies output voltage of the the built-in power supply
 b=1 - DC 5V
 b=2 - DC 12V
 b=4 - DC 48V
 b=5 - DC 48V and DC 5V
 b=6 - DC 48V and DC 12V
 b=7 - DC 48V and DC 12V ans DC 5V

specifies the input voltage, where:
 n=A - 230V AC / 50Hz

directly specifies total maximum power of the unit

Fiber Optic Products

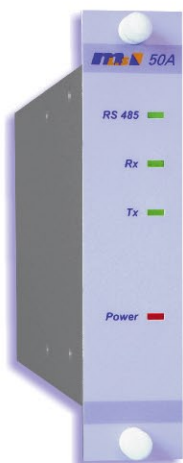

Series: *MLS 50A*

MONITORING LINE SYSTEM

Communicators



Communicators

MLS 50A

MLS 50A Communication unit

Brief characteristics :

- Communication interface between Ethernet LAN or WAN and a serial RS485 bus;
- TCP/IP protocols at the Ethernet side;
- MLS serial protocol at the side of the serial bus with up to 32 MLS active units;
- Without front panel setting of controlled measuring units;
- MLS 30 alarm status monitoring and its processing towards to the master PC or server;
- Integrated firewall ensures a secure communication LAN / WAN channel;
- Communication indicated on LED front panel;
- WEB interface for MLS 50A unit remote configuration;
- Power supply: 48VDC;
- Without display;
- Housing: single - wide, long module, LGX compatible.

Series: **MLS 50A**

MLS 50A

Communicator units - parameters

MLS unit		MLS50-A0-D
Display		NA
Front panel keyboard		NA
Interface RS 485		1
Interface MT-RJ		1
Local alarm signal		NA
Subsidiary voltage	V/A	NA
Power supply		
nominal voltage	V	48 (DC)
voltage range	V	18 - 72
Maximum consumption I _{max} .	mA	20
Typical consumption I _{typ} .	mA	10
Package	-	LGX 3U/1
Box dimensions (w x h x d)	mm	29 x 102 x 200

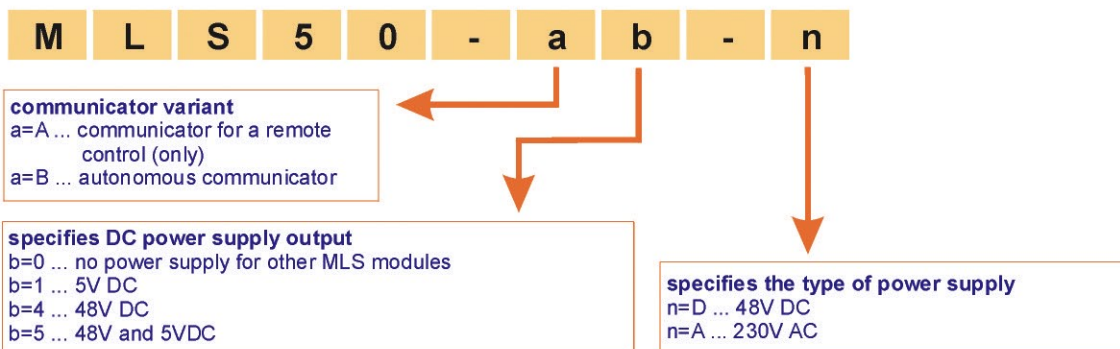

Fiber Optic Products



Series: **MLS 50B**

MONITORING LINE SYSTEM

Communicators



Communicators

MLS 50B

MLS 50B Autonomous communication unit



Brief characteristics :

- Communication interface between Ethernet LAN or WAN and serial RS485 bus;
- TCP/IP protocols at the Ethernet side;
- MLS serial protocol at the side of the serial bus with up to 32 MLS active units;
- Local station controlling and all MLS 30 unit variants management;
- Front panel display for setting and optical power reading on controlled MLS 30 measuring units;
- MLS 30 alarm status monitoring and its processing towards to the master PC or server;
- Integrated firewall ensures a secure communication LAN / WAN channel;
- Communication indicated on LED front panel;
- WEB interface for MLS 50A unit remote configuration;
- Local alarm signalling with possibility of external signalling attachment (relay output);
- Local configuration of the MLS 50B unit;
- Remote configuration of the MLS 50B unit via a WEB interface;
- Power supply: 230VAC or 48V DC;
- Optional subsidiary voltage output 5V DC/3 A;
- Subsidiary voltage output 48V DC/1 A (var A-D);
- Housing: 1 communication unit in 4-wide long LGX module.

Series: **MLS 50B**

MLS 50B

Communicator units - parameters

MLS unit		MLS50-B1-D	MLS50-B1-A	MLS50-B5-A
Display			YES	
Front panel keyboard			YES	
Interface RS 485			2	
Interface MT-RJ			1	
Local alarm signal		YES	YES	YES
Subsidiary voltage	V/A	5/2,5	5/2,5	5/2 48/0,4
Power supply nominal voltage	V	48 (DC)	230 (AC)	230 (AC)
voltage range	V	36 - 72		
Maximum consumption I _{max} .	mA	85	50	50
Typical consumption I _{typ} .	mA	80	45	45
Package	-	LGX 3U/4		
Box dimensions (w x h x d)	mm	117 x 102 x 200		

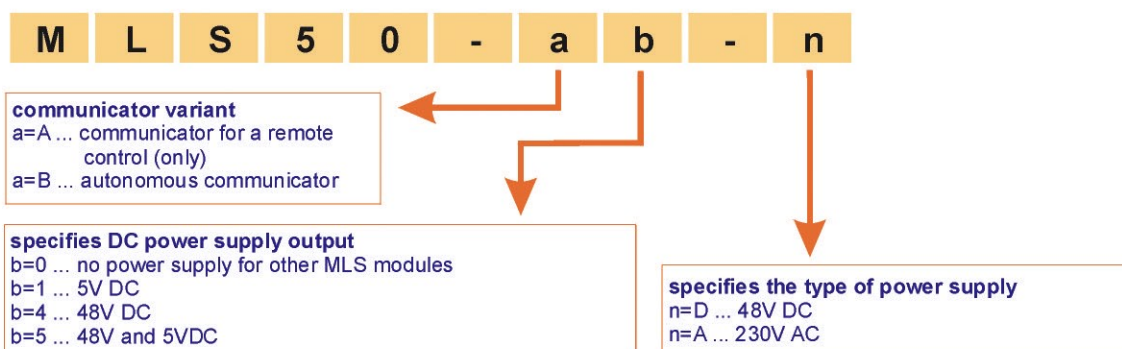

Fiber Optic Products

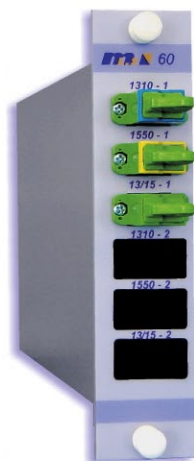

MONITORING LINE SYSTEM

WDM units MLS 60 series



WDM units

Type: **MLS 60-V2-0A-2E**

MLS 60-V2-0A-2E

Brief characteristics :

- Single-element WDM unit with frequently used pass and reflect wavelength ranges;
- Bi-directional add and drop operations;
- Working wavelength band 1310 nm;
- Monitoring wavelength band 1550 nm;
- Single-mode fiber;
- Low insertion loss and PDL, excellent reliability and environmental and mechanical stability;
- High spectral selectivity;
- E2000/APC optical line termination;
- One WDM 1x2 device in the unit;
- Housing: single - wide long module, LGX compatible.

Application :

- Active transmission and OTDR monitoring in the 1550 nm band on optical lines working in 1310 nm bands.

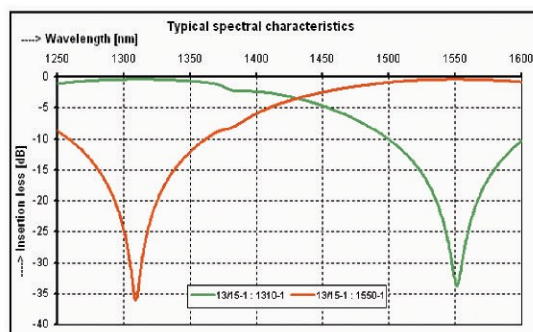

Type : **MLS 60-V2-0A-2E**

MLS 60-V2-0A-2E

Technical specifications

MLS 60-V2-0A-2E		
Working wavelength bands	nm	1295 - 1325
Monitoring wavelength band	nm	1535 - 1565
Fiber // connector type	μm	SM, 9/125 // E2000 / APC
Number of WDM devices in the module	-	1
Number of optical ports	-	3
Front panel marking	-	
- common ports		13/15-1
- working band ports		1310-1
- monitoring band ports		1550-1
Maximum/typical insertion loss between optical ports	dB	
13/15-1 : 1310-1		1,0 / 0,6
13/15-1 : 1550-1		1,0 / 0,6
Minimum/typical isolation between ports 13/15-1:1310-1 for @1550nm	dB	16 / 20
Minimum/typical isolation between ports 13/15-1:1550-1 for @1310nm	dB	16 / 20
Directivity	dB	typ. 50
Return Loss	dB	> 55
Working temperature	°C	from 0 to 40
Temperature stability	dB	< 0,2
Package	-	LGX 3U/1
Box dimensions (w x h x d)	mm	29 x 102 x 200

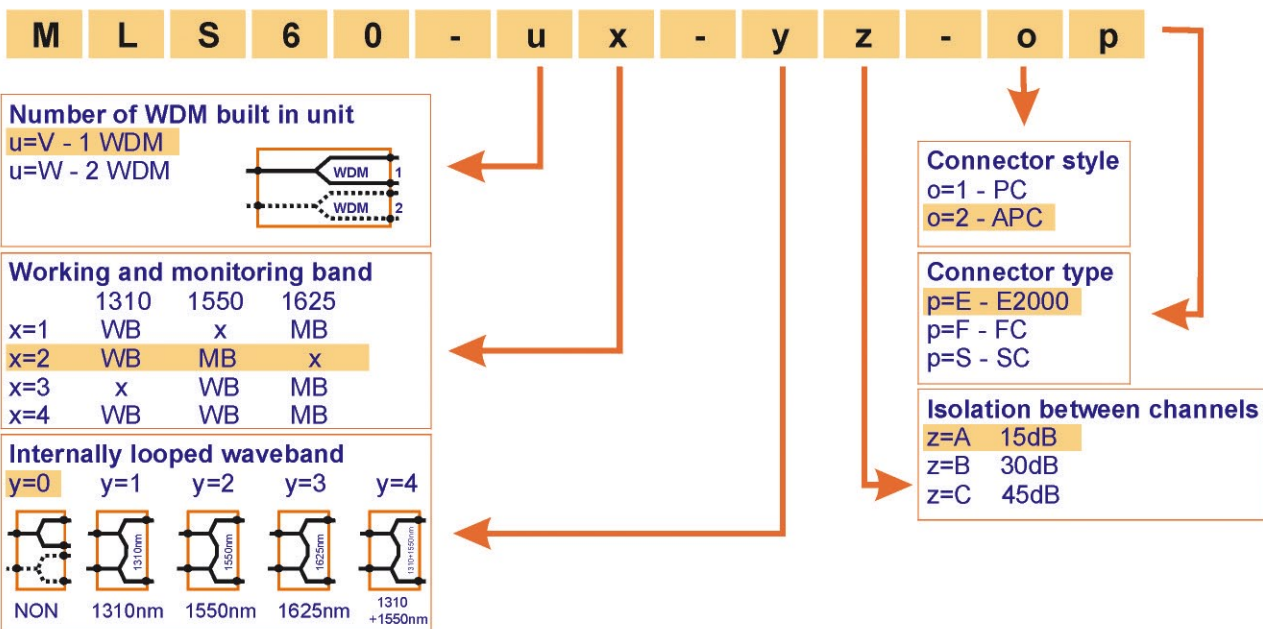

Fiber Optic Products



MONITORING LINE SYSTEM

WDM units MLS 60 series



WDM units

Type: **MLS 60-V4-0A-2E**

MLS 60-V4-0A-2E

Brief characteristics :

- Single-element WDM unit with extended pass and reflect wavelength ranges;
- Bi-directional add and drop operations;
- Working wavelength bands 1310nm and 1550nm;
- Monitoring (long wavelength) band: extended from 1610 nm to 1650 nm;
- Single-mode fiber;
- Low insertion loss and PDL, excellent reliability and environmental and mechanical stability;
- High spectral selectivity;
- E2000/APC optical line termination;
- One WDM 1x2 device in the unit;
- Housing: single - wide long, module, LGX compatible.

Application :

- Active transmission and OTDR monitoring in extended 1625 nm band on optical lines working in extended 1310 and 1550 nm bands.

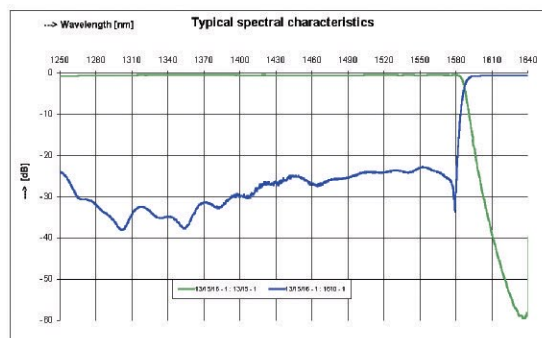

Type: **MLS 60-V4-0A-2E**

MLS 60-V4-0A-2E

Technical specifications

MLS 60-V4-0A-2E		
Working wavelength bands	nm	1260 - 1360 1480 - 1580
Monitoring wavelength band	nm	1610 - 1650
Fiber // connector type	μm	SM, 9/125 // E2000 / APC
Number of WDM devices in the module	-	1
Number of optical ports	-	3
Front panel marking	-	-
- common port		13/15/16-1
- working band ports		13/15-1
- monitoring band ports		1625-1
Maximum/typical insertion loss, between optical ports	dB	
13/15/16-1 : 13/15-1		1,6 / 1,0
13/15/16-1 : 1625-1		1,5 / 0,9
Minimum/typical isolation between ports 13/15/16-1:1625-1 for @1310nm and @1550nm	dB	22 / 25
Minimum isolation between ports 13/15/16-1 : 13/15-1	dB	
for @1610nm		25
for @1620nm		35
for @1630nm		40
for @1640nm		45
Directivity	dB	typ. 50
Return Loss	dB	> 55
Working temperature	°C	from 0 to 40
Temperature stability	dB	< 0,2
Package	-	LGX 3U/1
Box dimensions (w x h x d)	mm	29 x 102 x 200

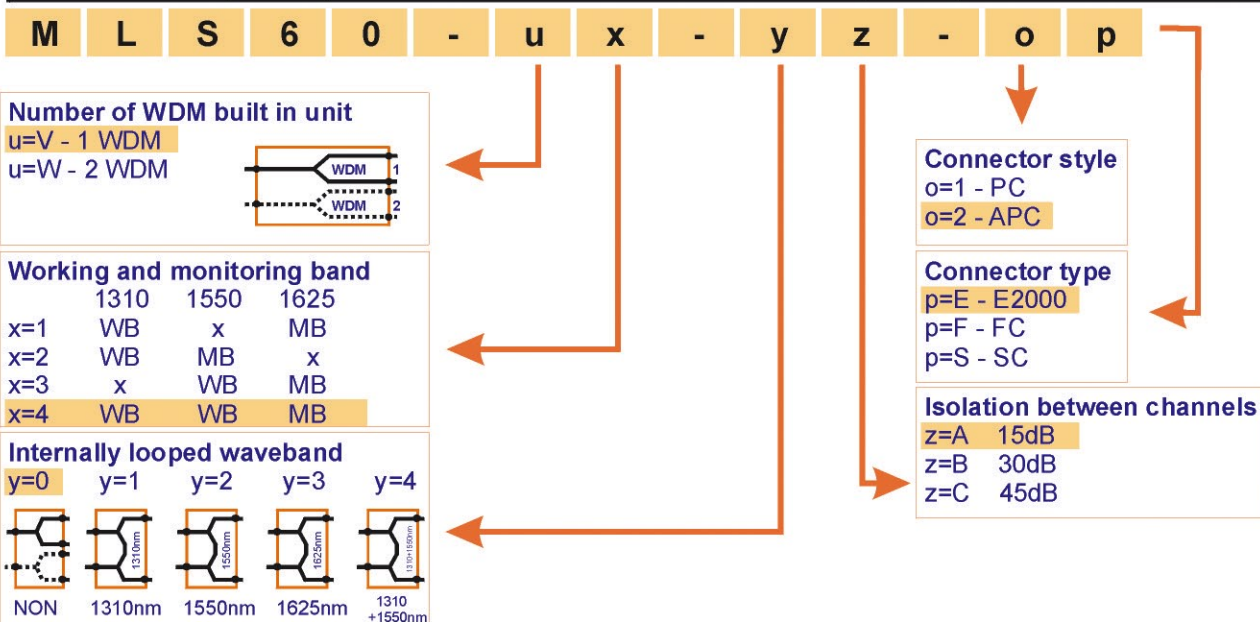

Fiber Optic Products

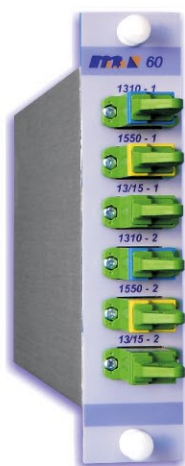

MONITORING LINE SYSTEM

WDM units MLS 60 series



WDM units

Type: **MLS 60-W2-0A-2E**

MLS 60-W2-0A-2E

Brief characteristics :

- Two-element WDM unit with frequently used pass and reflect wavelength ranges;
- Bi-directional add and drop operations;
- Working wavelength band 1310 nm;
- Monitoring wavelength band 1550 nm;
- Single-mode fiber;
- Low insertion loss and PDL, excellent reliability and environmental and mechanical stability;
- High spectral selectivity;
- E2000/APC optical line termination;
- Two WDM 1x2 devices in the unit;
- Housing: single - wide long module, LGX compatible.

Application :

- Active transmission and OTDR monitoring in the 1550 nm band on optical lines working in 1310 nm bands.

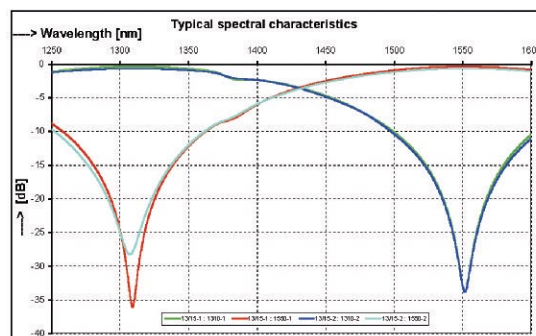

Type: **MLS 60-W2-0A-2E**

MLS 60-W2-0A-2E

Technical specifications

MLS 60-W2-0A-2E		
Working wavelength bands	nm	1295 - 1325
Monitoring wavelength band	nm	1535 - 1565
Fiber // connector type	μm	SM, 9/125 // E2000 / APC
Number of WDM devices in the module	-	2
Number of optical ports	-	6
Front panel marking	-	
- common ports		13/15-1 , 13/15-2
- working band ports		1310-1 , 1310-2
- monitoring band ports		1550-1 , 1550-2
Maximum/typical insertion loss between optical ports	dB	
13/15-1 : 1310-1 , 13/15-2 : 1310-2		1,0 / 0,6
13/15-1 : 1550-1 , 13/15-2 : 1550-2		1,0 / 0,6
Minimum/typical isolation between ports 13/15-1:1310-1, 13/15-2:1310-2 for @1550nm	dB	16 / 20
Minimum/typical isolation between ports 13/15-1:1550-1,13/15-2:1550-2 for @1310nm	dB	16 / 20
Directivity	dB	typ. 50
Return Loss	dB	> 55
Working temperature	°C	from 0 to 40
Temperature stability	dB	< 0,2
Package	-	LGX 3U/1
Box dimensions (w x h x d)	mm	29 x 102 x 200

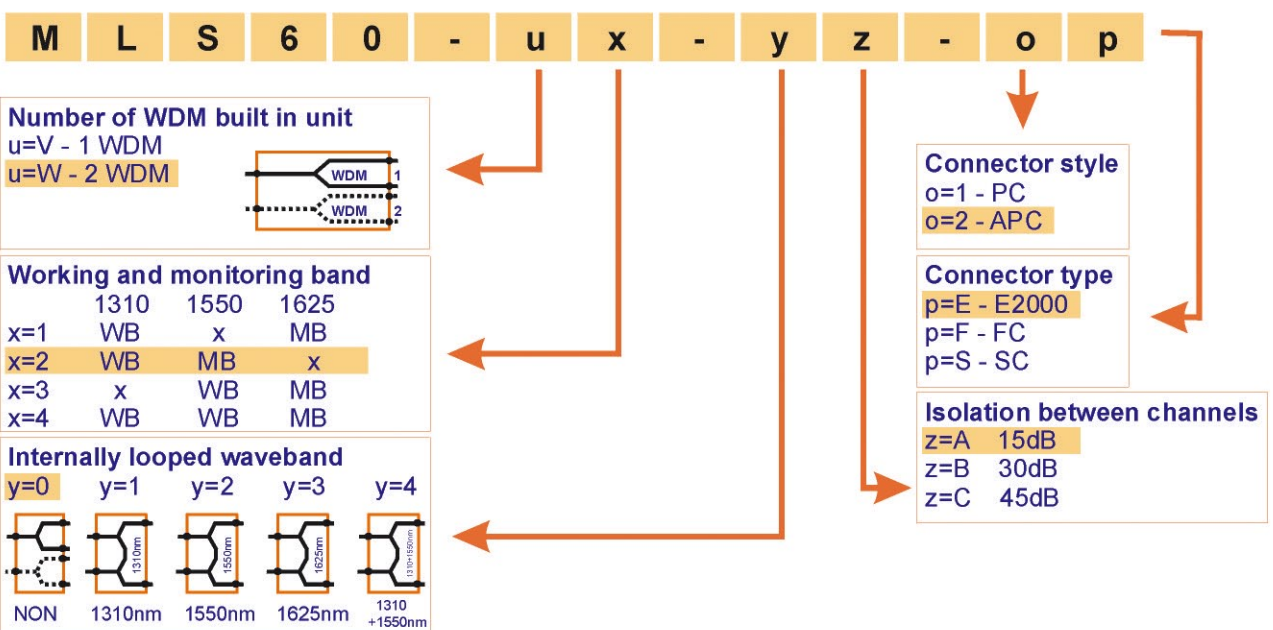

Fiber Optic Products



MONITORING LINE SYSTEM

WDM units MLS 60 series



WDM units

Type: **MLS 60-W2-1A-2E**

MLS 60-W2-1A-2E

Brief characteristics :

- Two-element WDM unit with frequently used pass and reflect wavelength ranges;
- Bi-directional add and drop operations;
- Working wavelength band 1310 nm internally looped;
- Monitoring wavelength band 1550 nm;
- Single-mode fiber;
- Low insertion loss and PDL, excellent reliability and environmental and mechanical stability;
- High spectral selectivity;
- E2000/APC optical line termination;
- Two WDM 1x2 devices in the unit;
- Housing: single - wide long module, LGX compatible.

Application :

- Active transmission and OTDR monitoring in the 1550 nm band on optical lines working in 1310 nm bands.

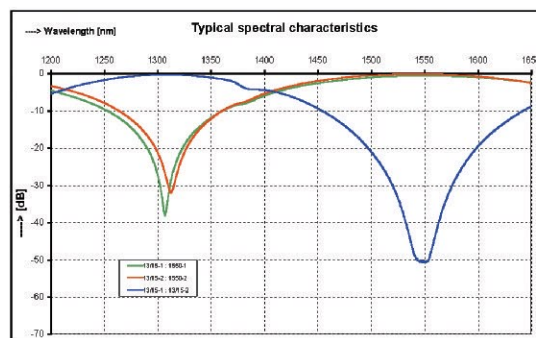

Type: **MLS 60-W2-1A-2E**

MLS 60-W2-1A-2E

Technical specifications

MLS 60-W2-1A-2E		
Working wavelength bands	nm	1295 - 1325
Monitoring wavelength band	nm	1535 - 1565
Fiber // connector type	μm	SM, 9/125 // E2000 / APC
Number of WDM devices in the module	-	2
Number of optical ports	-	4
Front panel marking	-	
- common ports		13/15-1 , 13/15-2
- monitoring band ports		1550-1 , 1550-2
Maximum/typical insertion loss between optical ports	dB	
13/15-1 : 13/15-2		1,4 / 1,0
13/15-1 : 1550-1 , 13/15-2 : 1550-2		1,0 / 0,6
Minimum/typical isolation between ports 13/15-1:13/15-2 for @1550nm	dB	32 / 40
Minimum isolation between ports 13/15-1:1550-1,13/15-2:1550-2 for @1310nm	dB	16
Directivity	dB	typ. 50
Return Loss	dB	> 55
Working temperature	°C	from 0 to 40
Temperature stability	dB	< 0,2
Package	-	LGX 3U/1
Box dimensions (w x h x d)	mm	29 x 102 x 200

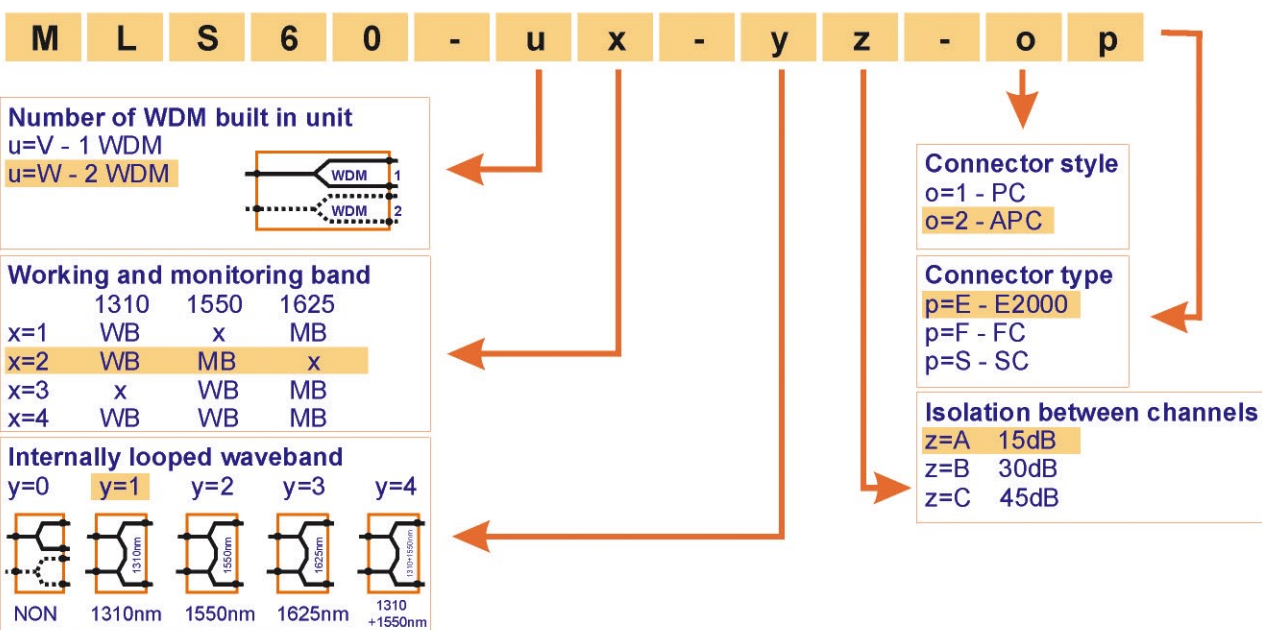

Fiber Optic Products



MONITORING LINE SYSTEM

WDM units MLS 60 series



WDM units

Type: **MLS 60-W2-2A-2E**

MLS 60-W2-2A-2E

Brief characteristics :

- Two-element WDM unit with frequently used pass and reflect wavelength ranges;
- Bi-directional add and drop operations;
- Working wavelength band 1310 nm ;
- Monitoring wavelength band 1550 nm internally looped;
- Single-mode fiber;
- Low insertion loss and PDL, excellent reliability and environmental and mechanical stability;
- High spectral selectivity;
- E2000/APC optical line termination;
- Two WDM 1x2 devices in the unit;
- Housing: single - wide, long module, LGX compatible.

Application :

- Active transmission and OTDR monitoring in the 1550 nm band on optical lines working in 1310 nm bands.

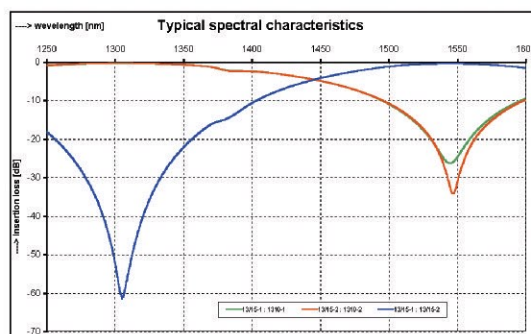

Type: **MLS 60-W2-2A-2E**

MLS 60-W2-2A-2E

Technical specifications

MLS 60-W2-2A-2E		
Working wavelength bands	nm	1295 - 1325
Monitoring wavelength band	nm	1535 - 1565
Fiber // connector type	μm	SM, 9/125 // E2000 / APC
Number of WDM devices in the module	-	2
Number of optical ports	-	4
Front panel marking	-	
- common ports		13/15-1 , 13/15-2
- monitoring band ports		1310-1 , 1310-2
Maximum/typical insertion loss between optical ports	dB	
13/15-1 : 13/15-2		1,4 / 1,0
13/15-1 : 1310-1 , 13/15-2 : 1310-2		1,0 / 0,6
Minimum/typical isolation between ports 13/15-1:13/15-2 for @1310nm	dB	32 / 40
Minimum isolation between ports 13/15-1:1310-1,13/15-2:1310-2 for @1550nm	dB	16
Directivity	dB	typ. 50
Return Loss	dB	> 55
Working temperature	°C	from 0 to 40
Temperature stability	dB	< 0,2
Package	-	LGX 3U/1
Box dimensions (w x h x d)	mm	29 x 102 x 200

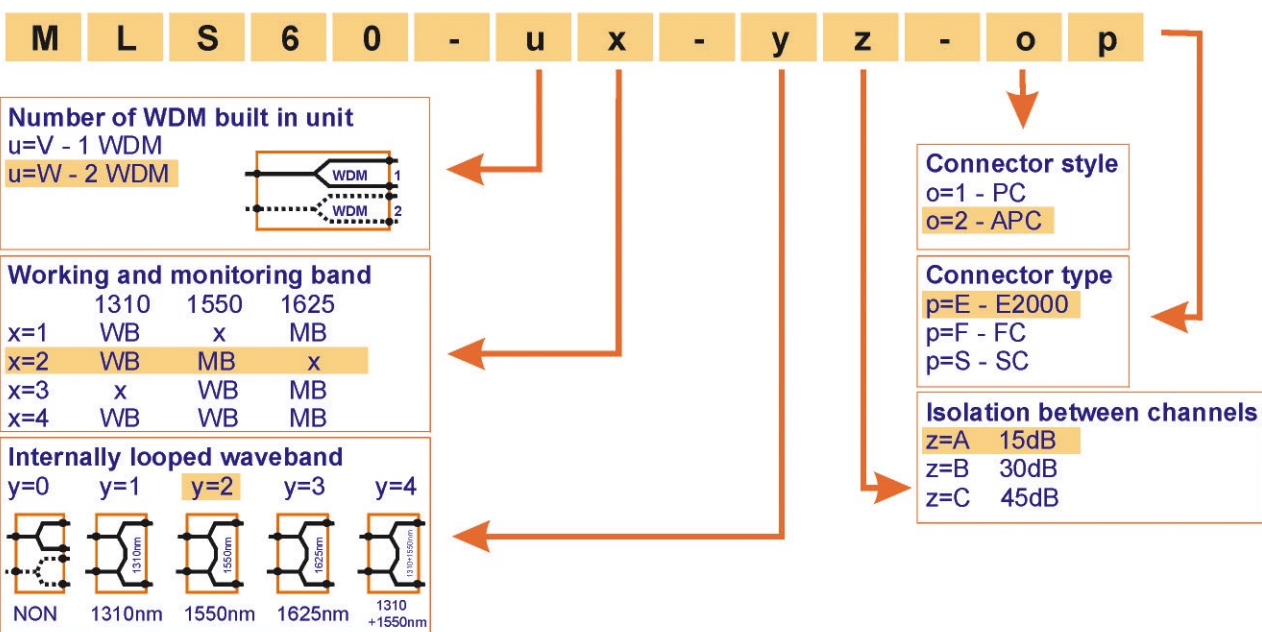

Fiber Optic Products



MONITORING LINE SYSTEM

WDM units MLS 60 series



WDM units

Type: **MLS 60-W4-0A-2E**

MLS 60-W4-0A-2E

Brief characteristics :

- Two-element WDM unit with extended pass and reflect wavelength ranges;
- Bi-directional add and drop operations;
- Working wavelength bands 1310nm and 1550nm;
- Monitoring (long wavelength) band: extended from 1610 nm to 1650 nm;
- Single-mode fiber;
- Low insertion loss and PDL, excellent reliability and environmental and mechanical stability;
- High spectral selectivity;
- E2000/APC optical line termination;
- Two WDM 1x2 devices in the unit;
- Housing: single - wide long module, LGX compatible.

Application :

- Active transmission and OTDR monitoring in extended 1625nm band on optical lines working in extended 1310 and 1550 nm bands.

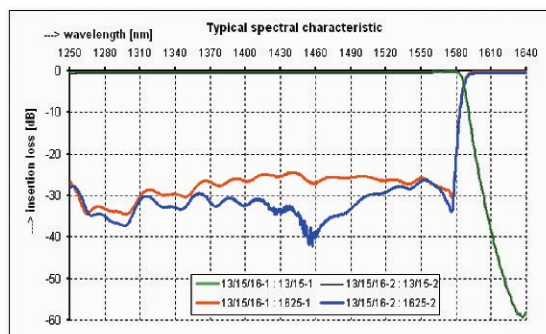

Type: **MLS 60-W4-0A-2E**

MLS 60-W4-0A-2E

Technical specifications

MLS 60-W4-0A-2E		
Working wavelength bands	nm	1260 - 1360 1480 - 1580
Monitoring wavelength band	nm	1610 - 1650
Fiber // connector type	μm	SM, 9/125 // E2000 / APC
Number of WDM devices in the module	-	2
Number of optical ports	-	6
Front panel marking	-	13/15/16-1 , 13/15/16-2
- common port		13/15-1 , 13/15-2
- working band ports		1625-1 , 1625-2
- monitoring band ports		
Maximum/typical insertion loss, between optical ports	dB	1,6 / 1,0 1,5 / 0,9
13/15/16-1 : 13/15-1 , 13/15/16-2 : 13/15-2		
13/15/16-1 : 1625-1 , 13/15/16-2 : 1625-2		
Minimum/typical isolation between ports 13/15/16-1:1625-1 for @1310nm and @1550nm	dB	22 / 25
Minimum isolation between ports 13/15/16-1:13/15-1, 13/15/16-2:13/15-2	dB	25
for @1610nm		35
for @1620nm		40
for @1630nm		45
for @1640nm		
Directivity	dB	typ. 50
Return Loss	dB	> 55
Working temperature	°C	from 0 to 40
Temperature stability	dB	< 0,2
Package	-	LGX 3U/1
Box dimensions (w x h x d)	mm	29 x 102 x 200

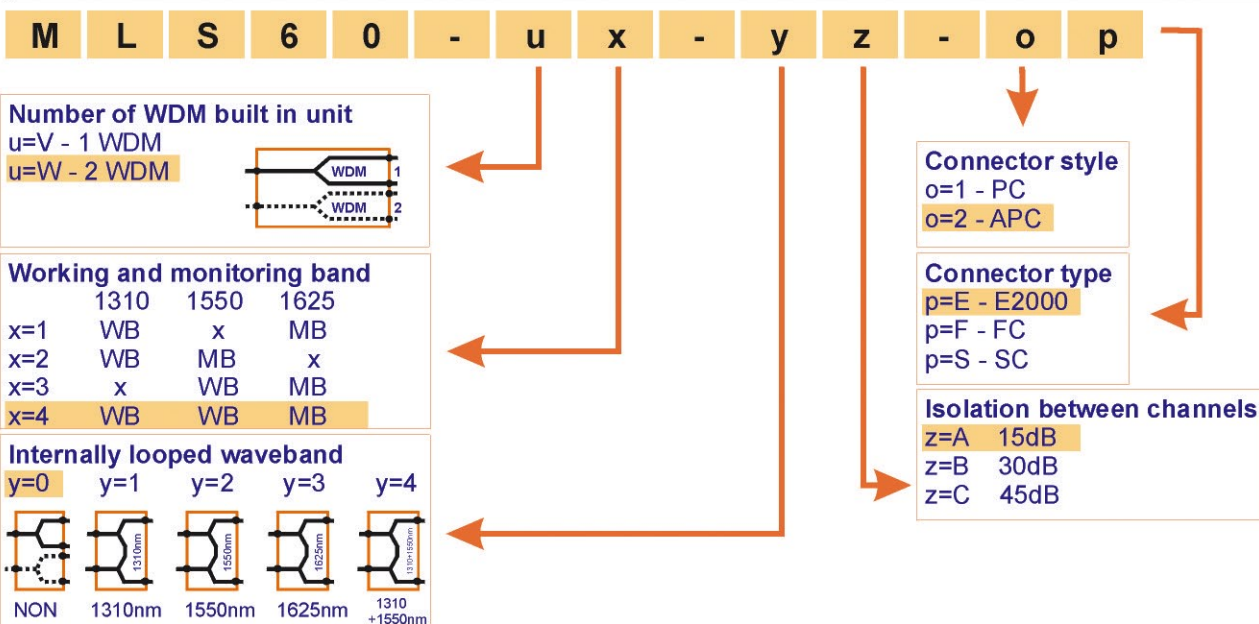

Fiber Optic Products



MONITORING LINE SYSTEM

WDM units MLS 60 series



WDM units

Type: **MLS 60-W4-3A-2E**

MLS 60-W4-3A-2E

Brief characteristics :

- Two-element WDM unit with extended pass and reflect wavelength ranges;
- Bi-directional add and drop operations;
- Working wavelength bands 1310 nm and 1550 nm;
- Monitoring wavelength band 1625 nm internally looped;
- Monitoring wavelength band extended from 1610 nm to 1650 nm;
- Single-mode fiber;
- Low insertion loss and PDL, excellent reliability and environmental and mechanical stability;
- High spectral selectivity;
- E2000/APC optical line termination;
- Two WDM 1x2 devices in the unit;
- Housing: single - wide long module, LGX compatible.

Application :

- Active transmission and/or OTDR monitoring in the 1625 nm band on optical lines working in 1310 nm and/or 1550 nm bands.

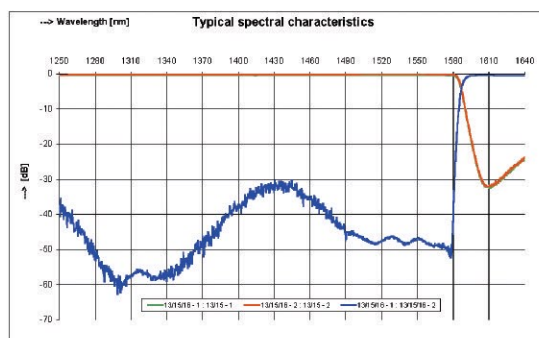

Type: **MLS 60-W4-3A-2E**

MLS 60-W4-3A-2E

Technical specifications

MLS 60-W4-3A-2E		
Working wavelength bands	nm	1260 - 1360 1480 - 1580
Monitoring wavelength band	nm	1610 - 1650
Fiber // connector type	μm	SM, 9/125 // E2000/APC
Number of WDM devices in the module	-	2
Number of optical ports	-	4
Front panel marking		
- common ports		13/15/16-1 , 13/15/16-2
- monitoring band ports		13/15-1 , 13/15-2
Maximum/typical insertion loss between optical ports 13/15/16-1 : 13/15-1 , 13/15/16-2 : 13/15-2 13/15/16-1 : 13/15/16-2	dB	1,6 / 1,0 2,4 / 1,6
Minimum/typical isolation between ports 13/15/16-1:13/15/16-2 for @1310nm and @1550nm	dB	44 / 50
Minimum isolation between ports 13/15/16-1:13/15-1, 13/15/16-2 :13/15-2 for @1610nm for @1620nm for @1630nm for @1640nm	dB	25 35 40 45
Directivity	dB	typ. 60
Return Loss	-	> 55
Working temperature	°C	from 0 to 40
Temperature stability	dB	< 0,2
Package	-	LGX 3U/1
Box dimensions (w x h x d)	mm	29 x 102 x 200

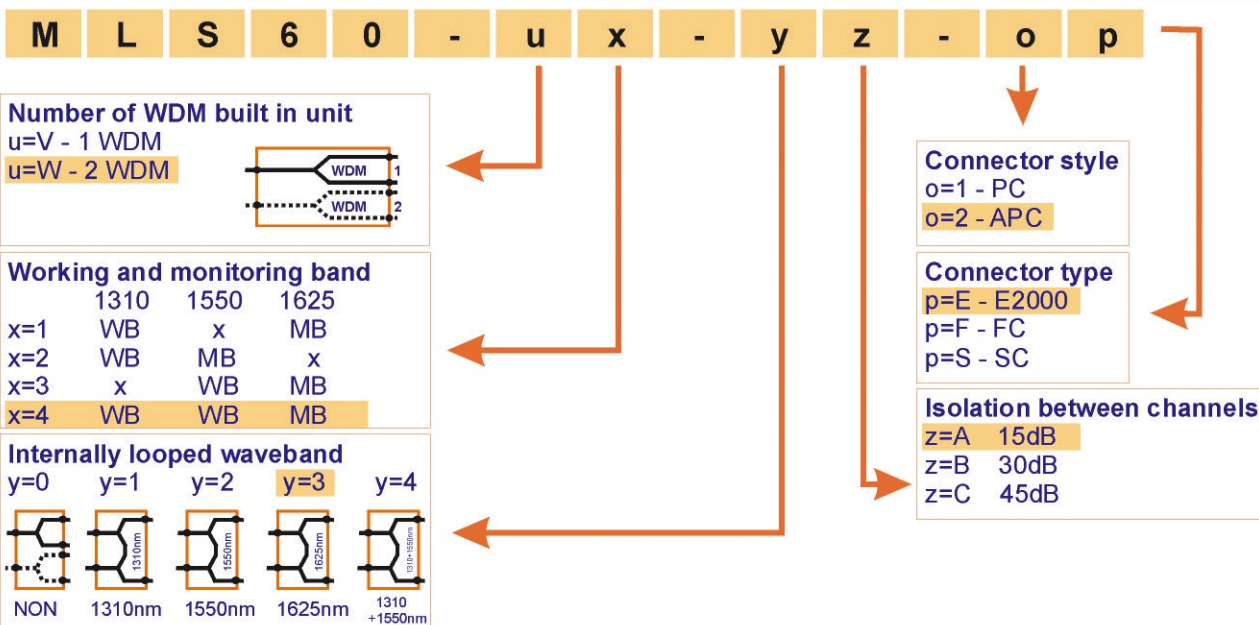

Fiber Optic Products



MONITORING LINE SYSTEM

WDM units



WDM units

Series: *MLS 60-W4-4A-2E*

MLS 60-W4-4A-2E

Brief characteristics :

- Two-element WDM unit with extended pass and reflect wavelength ranges;
- Bi-directional add and drop operations;
- Working wavelength bands 1310 nm and 1550 nm internally looped;
- Monitoring wavelength band 1625 nm;
- Monitoring wavelength band extended from 1610 nm to 1650 nm;
- Low insertion loss and PDL, excellent reliability and environmental and mechanical stability;
- High spectral selectivity;
- E2000/APC optical line termination;
- Two WDM devices 1x2 in long LGX module 1U.

Application :

- Active transmission and/or OTDR monitoring in the 1625 nm band on optical lines working in 1310 nm and/or 1550 nm bands.

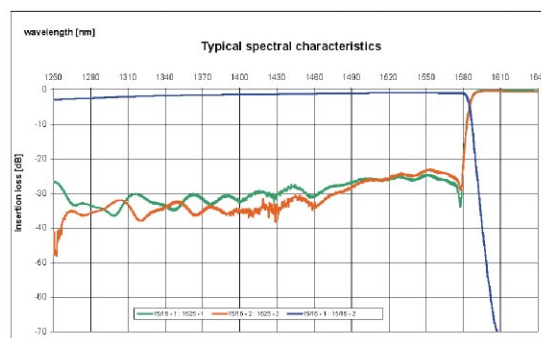

Type : **MLS 60-W4-4A-2E**

MLS 60-W4-4A-2E

Technical specifications

MLS 60-W4-4A-2E		
Working wavelength bands	nm	1260 - 1360 1480 - 1580
Monitoring wavelength band	nm	1610 - 1650
Fiber // connector type	μm	SM, 9/125 // E2000 / APC
Number of WDM devices in the module	-	2
Number of optical ports	-	4
Front panel marking	-	-
- common ports		13/15/16-1 , 13/15/16-2
- monitoring band ports		1625-1 , 1625-2
Maximum/typical insertion loss between optical ports	dB	
13/15/16-1 : 13/15/16-2		2,6 / 1,8
13/15/16-1 : 1625-1 , 13/15/16-2 : 1625-2		1,5 / 0,9
Minimum/typical isolation between ports 13/15/16-1 : 1625-1	dB	
13/15/16-2 : 1625-2 for @1310nm and @1550nm		22 / 25
Minimum isolation between ports 13/15/16-1 : 13/15/16-2	dB	
for @1610nm		50
for @1620nm		70
for @1630nm		80
for @1640nm		90
Directivity	dB	typ. 60
Return Loss	dB	> 55
Working temperature	°C	from 0 to 40
Temperature stability	dB	< 0,2
Package	-	LGX 3U/1
Box dimensions (w x h x d)	mm	29 x 102 x200

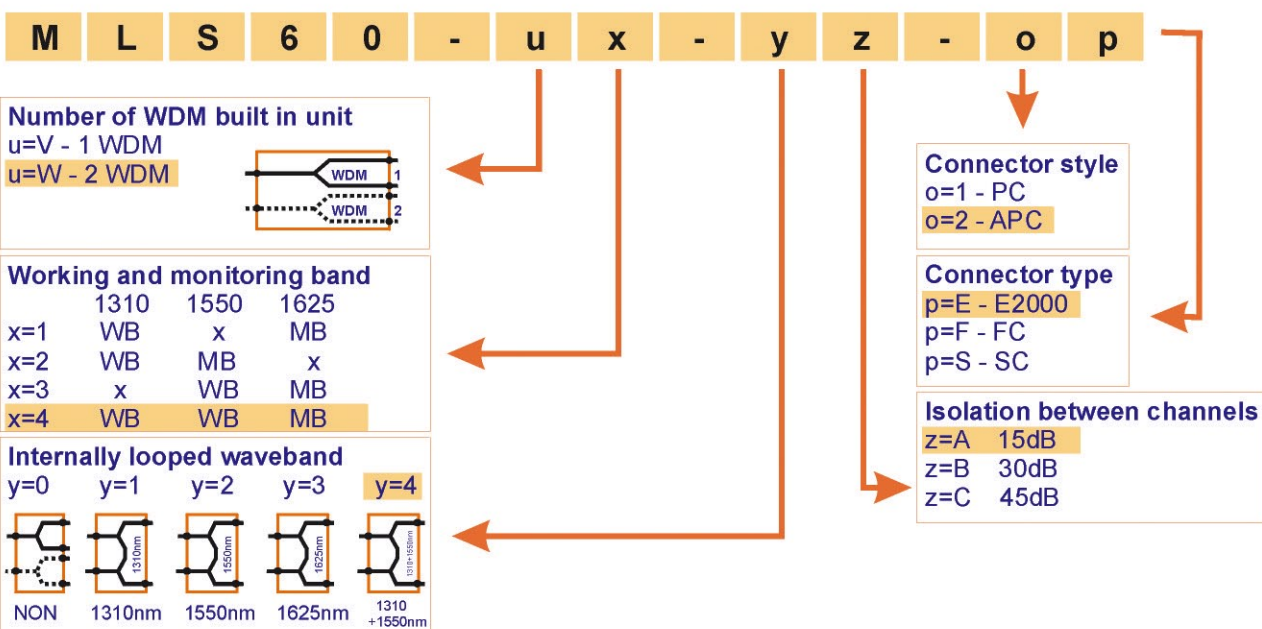

Fiber Optic Products



MONITORING LINE SYSTEM

ADD & DROP units



ADD & DROP units

Series: **MLS 60C**

MLS 60C

Brief characteristics :

- Bi-directional operations;
- Single mode fiber;
- Low insertion loss and PDL, excellent reliability and environmental and mechanical stability;
- High spectral selectivity;

- E2000/APC optical line termination;
- Built in the long 1LGX/3U;
- Specific CWDM channel ADD & DROP processing.

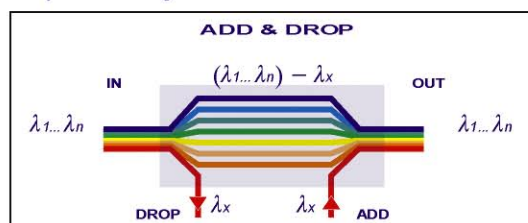

Application :

- Optical networks;
- Metro core, metro access, metro enterprise;
- Telecommunication systems;
- MLS CWDM program.

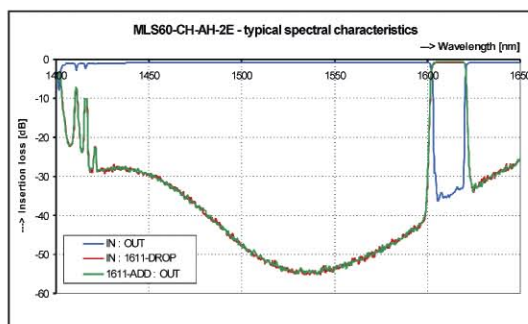

Type : **MLS 60C**

MLS 60C

Technical specifications

MLS 60-CO-AH-2E		
Working wavelength range	nm	1471/1491/1511/1531/1551/1571/1591/1611
ADD&DROP channel	nm	1611
Working wavelength bandwidth	nm	>13
Number of components in the module	-	1
Number of optical outlets of the module	-	4
Front panel labeling	-	1611-DROP, 1611-ADD, IN, OUT
Maximum / typical insertion loss between channels		
IN : OUT		2,0 / 1,1
IN : 1611-DROP		2,0 / 0,9
1611-ADD : OUT	dB	2,0 / 0,9
Isolation between adjacent channel		
IN : OUT - for channel 1611nm		> 30
IN : 1611-DROP - for channels from 1471 to 1591 nm		> 30
1611-DROP : OUT - for channels from 1471 to 1591 nm		> 30
1611-ADD : 1611-DROP	dB	> 40
Directivity	dB	> 55
Return loss (RL)	dB	> 55
Polarisation dependent loss (PDL)	dB	< 0,17
Fiber // connector type	µm	SM, 9/125 // E2000/APC
Operating temperature range	°C	from 0 to 40
Temperature stability**	dB	< 0,2
Housing	-	LGX 3U/1
Box dimension (w x h x d)	mm	29 x 102 x 200

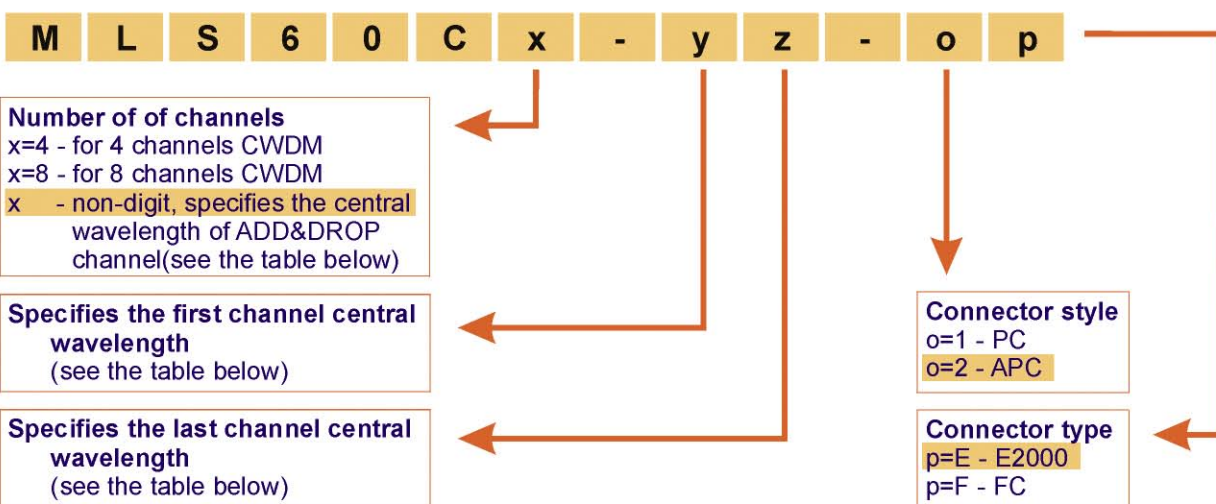

CWDM channel coding table: A = 1471nm E = 1551nm I = 1271nm M = 1351nm Q = 1431nm
 B = 1491nm F = 1571nm J = 1291nm N = 1371nm R = 1451nm
 C = 1511nm G = 1591nm K = 1311nm O = 1391nm
 D = 1531nm H = 1611nm L = 1331nm P = 1411nm

Fiber Optic Products



MONITORING LINE SYSTEM

CWDM units



CWDM units

Series: **MLS 60C**

MLS 60C

Brief characteristics :

- Bi-directional operations;
- May be used as multiplexer or demultiplexer;
- Single mode fiber;
- Low insertion loss and PDL, excellent reliability and environmental and mechanical stability;
- High spectral selectivity;
- E2000/APC optical line termination;
- Built in the long 2LGX/3U.

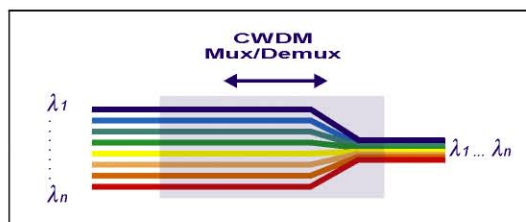

Application :

- Optical networks;
- Metro core, metro access, metro enterprise;
- Telecommunication systems;
- MLS CWDM program.

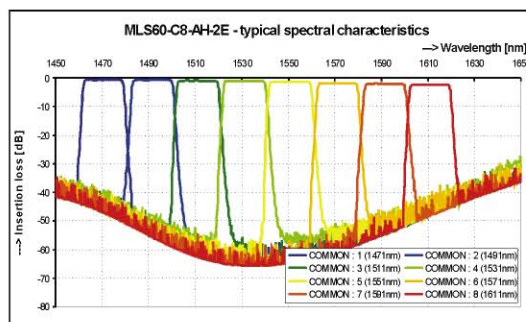

Type : **MLS 60C**

MLS 60C

Technical specifications

MLS 60-CO-AH-2E		MLS 60-C4-EH-2E	MLS 60-C8-AH-2E
Working wavelength range	nm	1551/1571/1591/1611	1471/1491/1511/1531/ 1551/1571/1591/1611
Working WL bandwidth	nm	>13	
Number of components in the module	-	1	
Number of optical outlets of the module	-	5	9
Front panel labeling	-	COMMON, 5, 6, 7, 8	COMMON, 1, 2, 3, 4, 5, 6, 7, 8
Maximum/typical insertion loss between channels COMMON : 1 (2, 3, 4, 5, 6, 7, 8)	dB	1,6	3,0
Passband ripple	dB	< 0,3	
Isolation between adjacent channels	dB	> 30	
Isolation between non-adjacent channels	dB	> 40	
Directivity	dB	typ. 55	
Return loss (RL)	dB	> 45	
Polarisation dependent loss (PDL)	dB	< 0,17	
Fiber // connector type	μm	SM, 9/125 // E2000/APC	
Operating temperature range	°C	from 0 to 40	
Temperature stability	dB	< 0,2	
Housing	-	LGX 3U/2 *	LGX 3U/2
Box dimensions (w x h x d)	mm	59 x 102 x 200	

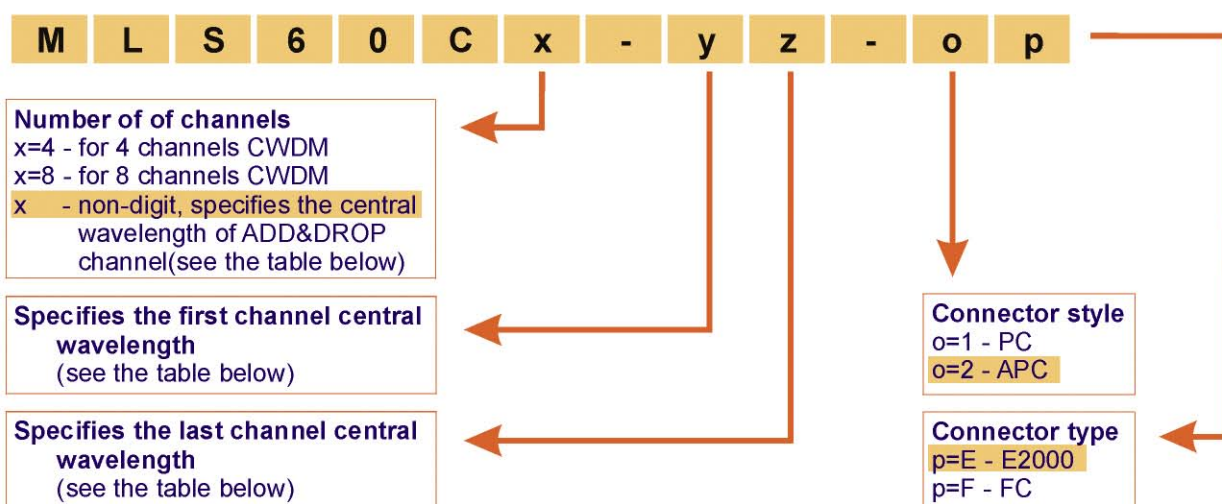

CWDM channel coding table: A = 1471nm E = 1551nm I = 1271nm M = 1351nm Q = 1431nm
 B = 1491nm F = 1571nm J = 1291nm N = 1371nm R = 1451nm
 C = 1511nm G = 1591nm K = 1311nm O = 1391nm
 D = 1531nm H = 1611nm L = 1331nm P = 1411nm

Fiber Optic Products



MONITORING LINE SYSTEM

Line doubler



Line doubler

Series: **MLS 60L**

MLS 60L

Brief characteristics :

- Low insertion loss;
- High isolation;
- Ultra low values PDL and PMD;
- Excellent reliability, environmental and mechanical stability;
- E2000/APC or SC/PC optical line termination;
- Wide operating wavelength and temperature range;
- Built in the 1LGX/3U module.

Application :

- WDM and DWDM systems;
- Fiber optic instruments;
- Transmitters and fiber lasers;
- Dispersion compensation.

Series : **MLS 60L**

MLS 60L

Technical specifications

MLS unit		MLS60-L1-0A-2E 1310-1550	MLS60-L1-0C-2E 1310-1550	MLS60-L1-0A-2E 1550-1310	MLS60-L1-0C-2E 1550-1310
Fiber // connector type	-	SM, 9/125 // E2000/APC			
Number of devices in the unit	-	1	1	1	1
Number of optical ports	-	5	5	5	5
Front panel marking	-	Line, Tx 1310, Rx 1310, Tx 1550, Rx 1550			
Working wavelength (lowest IL band)	nm	1310	1310	1550	1550
Minimum/typical isolation 1310 nm: Line ->Rx 1550 1550 nm: Line ->Rx 1310	dB	15 / 22	30 / 40	15 / 22	30 / 40
Directivity TX 1310 ->Rx 1310 TX 1550 ->Rx 1550	dB	> 50			
Maximum/typical insertion loss Tx 1310 <-> Line	dB	1,6 / 0,8	1,8 / 0,9	3,5 / 2,7	3,7 / 2,9
Maximum/typical insertion loss Tx 1550 <-> Line	dB	3,5 / 2,7	3,7 / 2,9	1,6 / 0,8	1,8 / 0,9
Polarisation dependent loss (PDL)	dB	< 0,15			
Polarisation mode dispersion (PMD)	ps	< 0,1			
Return loss (RL)	dB	> 50			
Operating temperature range	°C	from 0 to 40			
Temperature stability	dB	< 0,2			
Housing	-	LGX 3U/1			
Box dimensions (w x h x d)	mm	29 x 102 x 200			

M L S 6 0 L x - y z - o p Ch1 - Ch2

Number of doublers in a box
x= directly specifies number of doublers in a box

y - 0 (reserved)

Specifies isolation between channels
z=A - isolation = 15 dB
z=B - isolation = 30 dB
z=C - isolation = 45 dB

Connector style
o=1 - PC
o=2 - APC

Connector type
p=E - E2000
p=F - FC

Ch1 - directly specifies wavelength of the optimized channel (the channel for lower IL), in nm

Ch2 - directly specifies wavelength of the second channel in nm

Fiber Optic Products



MONITORING LINE SYSTEM

Optical circulators



Optical circulators

Series: *MLS 70C*

MLS 70C

Brief characteristics :

- Low insertion loss;
- High isolation;
- Ultra low values PDL and PMD;
- Excellent reliability and environmental and mechanical stability;
- E2000/APC optical line termination;
- Built in the long LGX modules 3U/1 and 3U/2.

Application :

- WDM and DWDM systems;
- Fiber optic instruments;
- Transmitters and fiber lasers;
- Dispersion compensation.

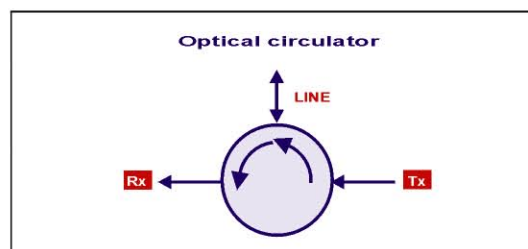

Series: **MLS 70C**

MLS 70C

Technical specifications

MLS unit		MLS 70-C0-3SD-2E	MLS 70-C0-3DD-2E	MLS 70-C1-3SD-2E	MLS 70-C1-3DD-2E
Fiber // connector type	[-]	SM, 9/125 // E2000/APC			
Number of devices in the unit	[-]	1	2	1	2
Number of optical ports	[-]	3	6	3	6
Front panel marking		Tx1, Line1, Rx1	Tx1, Line1, Rx1 Tx2, Line2, Rx2	Tx1, Line1, Rx1	Tx1, Line1, Rx1 Tx2, Line2, Rx2
Center wavelength λ_c	[nm]	1310		1550	
Minimum/typical isolation ($\lambda_c \pm 20$ nm) Line->Tx , Rx->Line	[dB]	40 / 50			
Maximum/typical insertion loss ($\lambda_c \pm 20$ nm) Tx->Line , Line->Rx	[dB]	1,1 / 0,6			
Directivity	[dB]	> 50			
Polarisation dependent loss (PDL)	[dB]	< 0,15			
Polarisation mode dispersion (PDM)	[ps]	$\leq 0,1$			
Wavelength dependent loss (WDL)	[dB]	$\leq 0,2$			
Return loss (RL)	[dB]	> 50			
Operating temperature	[°C]	from 0 to 40			
Temperature stability	[dB]	$\pm 0,1$			
Housing	[-]	LGX 3U/1			
Weight	[kg]	0,3	0,35	0,3	0,35

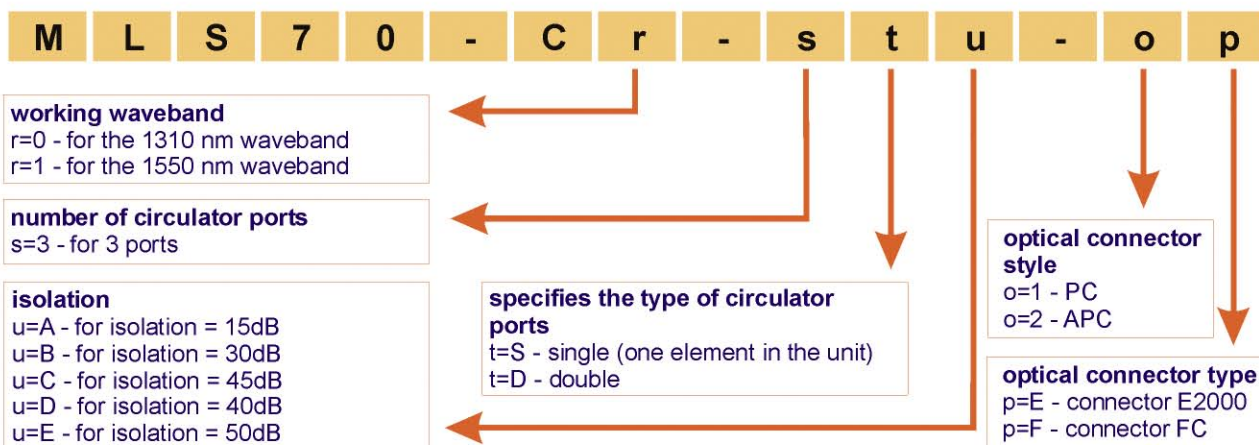

Fiber Optic Products

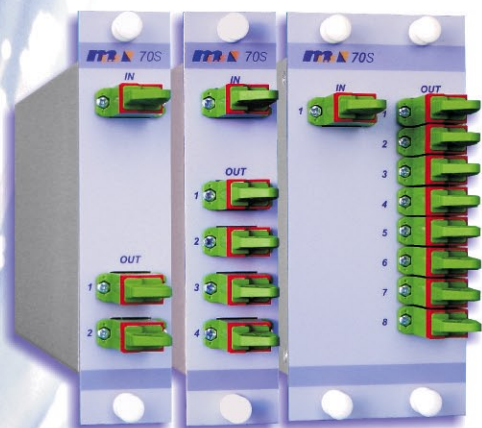

MONITORING LINE SYSTEM

Optical splitters



Optical splitters

Series: *MLS 70S*

MLS 70S

Brief characteristics :

- Bi-directional split and coupling operations;
- Broad spectral range of 1310/1550 nm bands;
- Single-mode fiber;
- E2000/APC optical line termination;
- One band, two or three bands operation (fusion technology) or ultra broadband planar splitters variants;
- Low insertion loss, return loss and PDL;
- Excellent reliability and environmental and mechanical stability;
- Housing: single or double - wide long module, LGX module compatible.

Application :

- Test signal distribution in the active transmission monitoring;
- Optical testing and measurements;
- Local monitoring of a light source output;
- Distributing a common data signal to several locations simultaneously;
- FTTH PON Systems.

Series: **MLS 70S**

MLS 70S

Technical specifications

MLS planar splitter units		MLS 70-S4-1A2-2E	MLS 70-S4-1A4-2E	MLS 70-S4-1A8-2E
Fiber // connector type	μm	SM, 9/125 // E2000/APC		
Number of optical ports	-	3(1+2)	5(1+4)	9(1+8)
Working wavelength bands	nm	1200 ÷ 1640 and 1480 ÷ 1650		
Maximum / typical insertion loss (IL)*	dB	4,4 / 3,9	7,8 / 7,2	11,3 / 10,4
Polarisation dependent loss (PDL)	dB	< 0,2		
Uniformity (max.)	dB	0,3	0,5	0,7
Return loss (RL)	dB	> 55		
Directivity	dB	> 55		
Temperature stability*	dB	< 0,2		
Working temperature	°C	0 ÷ 40		
Package	-	LGX 3U/1		LGX3U/2
Box dimensions (w x h x d)	mm	29 x 102 x 200		59 x 102 x 200

* splices and connectors included

MLS fused splitter units		MLS 70-S2-1A2-2	MLS 70-S2-1E2-2E	MLS 70-S2-1A4-2E
Fiber // connector type	μm	SM, 9/125 // E2000/APC		
Number of optical ports	-	3(1+2)	3(1+2)	5(1+4)
Working wavelength bands	nm	1270 ÷ 1350 and 1510 ÷ 1590		
Maximum / typical insertion loss (IL)*	dB	4,1 / 3,2	11,8 / 11,4 (for 10%) 1,1 / 0,8 (for 90%)	7,7 / 7,0
Polarisation dependent loss (PDL)	dB	< 0,15		
Uniformity (typical)	dB	0,7	-	1,1
Temperature stability*	dB	< 0,2		
Working temperature	°C	0 ÷ 40		
Package	-	LGX 3U/1		
Box dimensions	mm	29 x 102 x 200		

* splices and connectors included

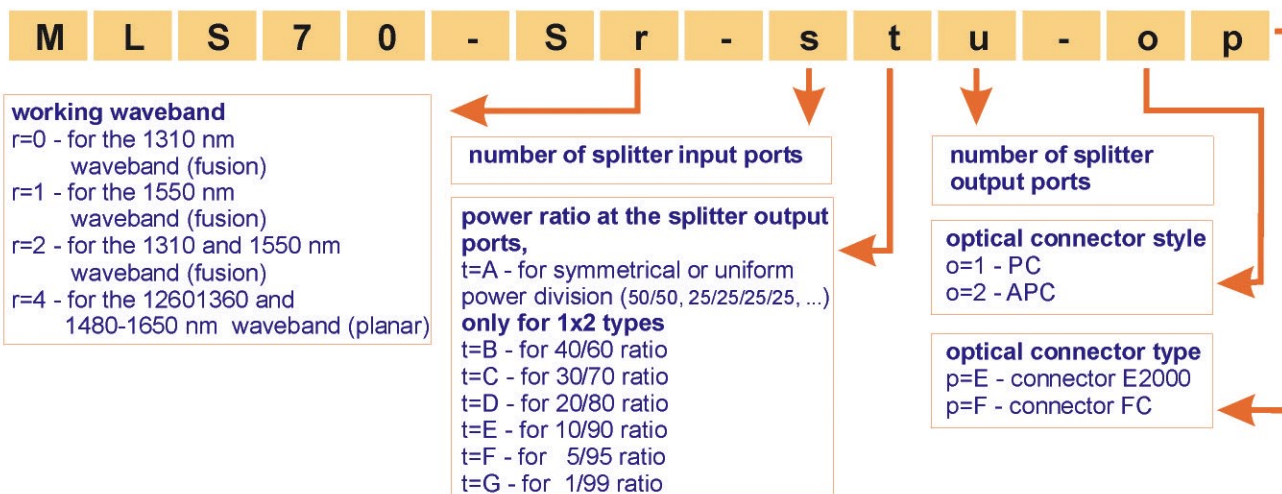

Fiber Optic Products

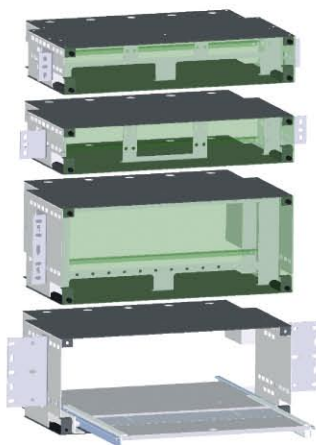

MONITORING LINE SYSTEM

LGX style chassis and OTDR chassis



LGX style chassis and OTDR chassis

Series: **MLS 80**

MLS 80

- **Brief characteristics MLS80-2U-01**
· Metal rack for three 1LGX/3U boxes (in horizontal position);
- **Brief characteristics MLS80-2U-02**
· Metal rack for up to three 2LGX/3U boxes or up to six 1LGX/3U (in horizontal position);
- **Brief characteristics MLS80-4U-01**
· Metal rack for up to twelve 1LGX/3U modules (in total width);
- **Brief characteristics MLS80-4U-02**
· Metal rack for MLS400 (OTDR);



Brief characteristics :

- Designed with sufficient space for cable reserves in lower part;
- Front panel covered with removable acrylic sheet;
- Compatible with 19" and 21" rails (various holders available).

Series: **MLS 80**

MLS 80



MLS 80-2U-01

- 2U chassis with holders mounted for 19" rail spacing, version for 3 boxes 1LGX/3U

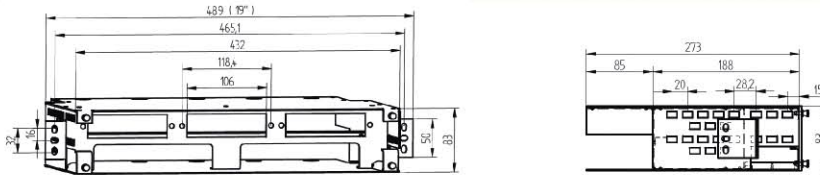

MLS 80-2U-02

- 2U chassis with holders mounted for 21" rail spacing, version for up 3 boxes 2LGX/3U (6 boxes 1LGX/3U)

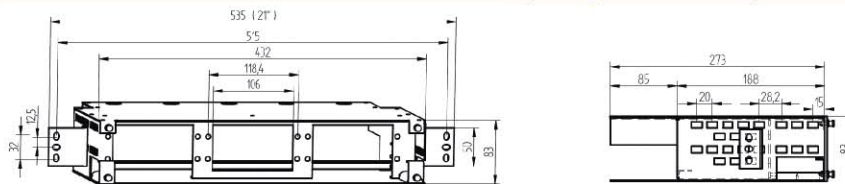

MLS 80-4U-01

- 4U chassis with holders mounted for 19" rail spacing, version for up 12 boxes 1LGX/3U

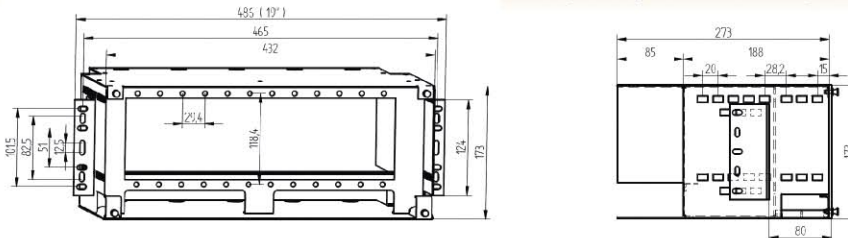

MLS 80-4U-02

- 4U chassis with holders mounted for 21" rail spacing, version for units MLS400 (OTDR)

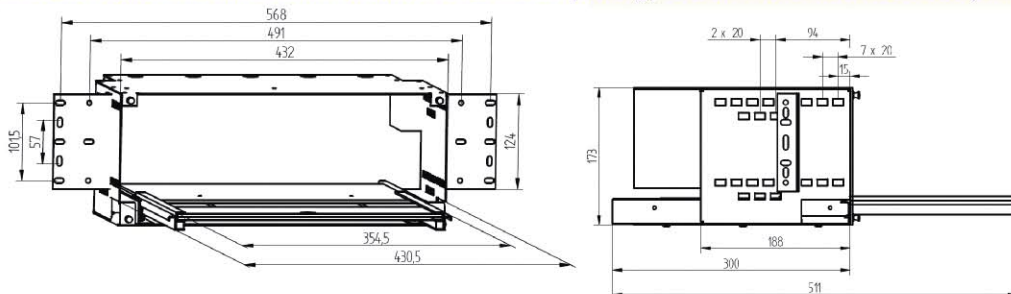

M L S 8 0 - p U - x y

p - specifies the high of the chassis, where U=4,45 cm and
 p=2 - for high = 2U
 p=3 - for high = 3U
 p=4 - for high = 4U

xy - is an identifier of the version according to the design drawings

For details see *MLS technical specifications* (<http://www.sqs-fiber.cz>).

Fiber Optic Products

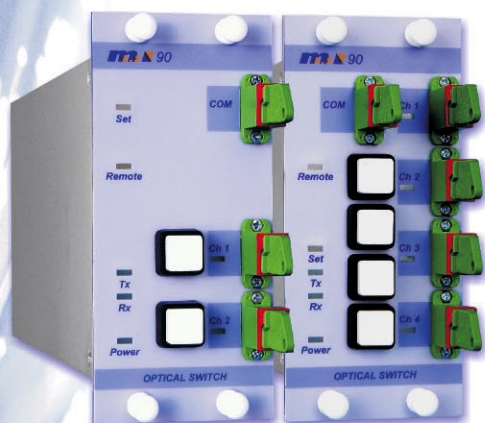

MONITORING LINE SYSTEM

Optical switches



Optical switches

Series: **MLS 90-O**

MLS 90-O

Brief characteristics :

- Optical switches 1 x 2, 1 x 4, with fast response;
- Remote or on-site control via the RS485 interface;
- Lockable manual control from the front panel;
- Front panel signalling;
- Long-term stable operation;
- Wave-length range from 1260 to 1650 nm;
- Power supply voltage 48V DC (nom.);
- Optical switch position immune to power supply interruptions;
- Two-state control by an external contact available for switches 1 x 2;
- Housing: double - wide long module, LGX compatible.

Application :

- Optical testing and measurement;
- Fiber optic sensing;
- Essential component in backed-up transmission routes;
- Network fault protection;
- Laboratory testing and measuring equipment;
- Optical testing access unit (OTAU);
- Enables other measuring equipment to be shared by more optical routes;
- Enables to combine measurement methods, generally;
- Enables to combine transmitting method (TM) and OTDR measurement (ARFTS).

Series: **MLS 90-O** **MLS 90-O**

Optical switch units - parameters

MLS unit		MLS 90-O1-D 1 x 2	MLS 90-O2-D 1 x 2	MLS 90-O1-D 1 x 4	MLS 90-O2-D 1 x 4
Number of optical channels	-	2	2	4	4
Number of optical ports	-	3	3	5	5
Wave-length range	nm	850/1300	1280 - 1340 1520 - 1625	850/1300	1280 - 1340 1520 - 1625
Fiber type	-	MM	SM	MM	SM
Insertion loss typical / maximum	dB	0,9 / 1,2	0,9 / 1,3	1,5 / 2,1	1,5 / 2,3
Return loss	dB	-	≥ 45	-	≥ 45
PDL	dB	-	< 0,1	-	< 0,1
Crosstalk	dB	≥ 80			
Repeatability (for constant temperature)	dB	± 0,03		±0,05	
Transition time [*]	ms	< 10	< 5	< 10	< 5
Time of the command batch [*]	ms	22			
Response time [*]	ms	< 42	< 37	< 42	< 37
External contact response time [*]	ms	< 20	< 15	-	-
Guaranteed lifetime (cycles)	-	> 10 ⁷			
Connector type	-	E2000/APC			
Stability (in whole temperature range)	dB	±0,2		±0,4	
Stability (within ±3 deg. temp. range)	dB	±0,1		±0,2	
Operating temperature	°C	from 0 to 40			
Power supply nominal voltage	V	48 (DC)			
voltage range	V	18 ÷ 72 (DC)			
Maximum power consumption	W	1,5			
Typical power consumption	W	1,2			
Box dimensions (w x h x d)	mm	59 x 102 x 200			

^{*} Time of optical power transitions in optical channels during the switching phase.

^{*} Time of uninterrupted command batch as received from the serial line of 9600 Bd data rate.

^{*} Total switching time from the beginning of the command batch to the end of transitions in optical channels.

^{*} Valid for 1 x 2 switches only, when driven by external contact.

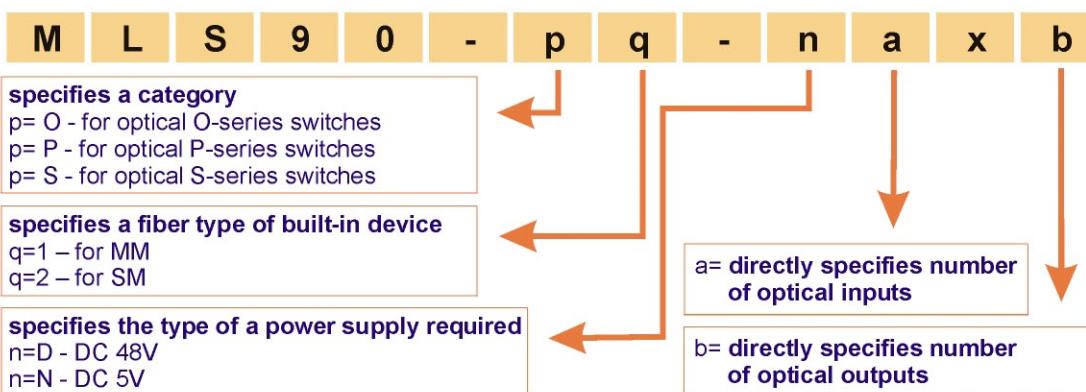

Fiber Optic Products



MONITORING LINE SYSTEM



Optical switches
1x4, 1x8 and 1x12

Optical switches
1x4, 1x8 and 1x12

Series: **MLS 90-P**

MLS 90-P

Brief characteristics :

- Optical switches 1x4, 1x8 and 1x12 with fast response;
- Remote control via RS485 bus;
- Local control from the front panel (blockable);
- Long-term stability;
- Wavelength range from 1200 to 1650 nm;
- Communication, status and position indicated on the front panel;
- Power supply 48V DC;
- Housing: long LGX / 3U module.

Application :

- Optical testing and measurement;
- Fiber optic sensing;
- Essential component in backed-up transmission routes;
- Network fault protection;
- Laboratory testing and measuring equipment;
- Optical testing unit (OTAU);
- Enables to other measuring equipment to be shared by more optical routes;
- Enables to combine measurement methods, generally;
- Enables to combine transmitting method (TM) and OTDR measurement (ARFTS).

Series: **MLS 90-P**

MLS 90-P

Optical switch units - parameters

MLS unit		MLS 90-P2-D 1x4	MLS 90-P2-D 1x8	MLS 90-P2-D 1x12 (preliminary)
Number of optical channels	-	4	8	12
Number of optical ports	-	5	9	13
Band	nm	1200 - 1650		
Fiber type	-	SM 9/125		
Insertion loss (typical / maximum)	dB			
- in band 1260-1360 nm				
- in band 1480-1600 nm				
- in band 1200-1650 nm				
Return loss	dB	> 65		
PDL	dB	< 0,1		
Crosstalk	dB	> 55		
Repeatability	dB	< 0,005		
Response	ms	< 36		
Lifetime (cycles)	-	> 10 ⁷		
Connector type	-	E2000/APC		
Stability (in whole temperature range)	dB	±0,15		
Stability (in temp. band of ±3 °C)	dB	±0,05		
Operating temperature range	°C	from 0 to 40		
Power supply voltage				
- nominal	V	48 (DC)		
- range	V	18 - 72 (DC)		
Maximum consumption	W	1,8		
Typical consumption	W	1,5		
Control interface	-	RS 485		
Weight	kg	0,85	0,9	x
Housing	-	2LGX / 3U		3LGX / 3U

M L S 9 0 - P q - n a x b

specifies a category

p= O - for optical O-series switches
 p= P - for optical P-series switches
 p= S - for optical S-series switches

specifies a fiber type of built-in device

q=1 – for MM
 q=2 – for SM

specifies the type of a power supply required

n=D - DC 48V
 n=N - DC 5V

a= directly specifies number
of optical inputs

b= directly specifies number
of optical outputs

Fiber Optic Products

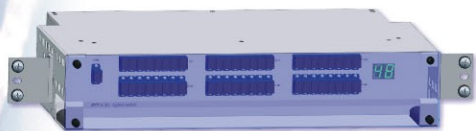

MONITORING LINE SYSTEM

Optical switches



Optical switches

Series: *MLS 90-S*

MLS 90-S

Brief characteristics :

- Optical switches 1 x 24, 1 x 32 and 1 x 48;
- Remote control via the RS485 and RS232 interfaces;
- Front panel signalling;
- Long-term stable operation;
- Wave-length range from 1200 to 1650 nm;
- Power supply voltage 48V DC (nom.);
- Housing: 2U chassis to 19" and 21" rails;
- Latching or non-latching operating modes.

Application :

- Optical testing and measurement.
- Fiber optic sensing.
- Laboratory testing and measuring equipment.
- Optical testing access unit (OTAU).
- Enables other measuring equipment to be shared by more optical routes.
- Enables to combine measurement methods, generally.
- Enables to combine transmitting method (TM) and OTDR measurement.

Series: **MLS 90-S**

MLS 90-S

Optical switch units - parameters

MLS unit		MLS90-S2-2D 1x24 PC	MLS90-S2-2D 1x32 PC	MLS90-S2-2D 1x48 PC
Number of optical channels	-	24	32	48
Number of optical ports	-	25	33	49
Band	nm	1200 - 1650		
Fiber type	-	SM 9/125/900		
Insertion loss (typical / maximum)	dB	0,8 / 1,5		
Return loss (typical / maximum)	dB	>60 / >55		
PDL	dB	< 0,1		
Crosstalk (typical / maximum)	dB	>80 / >70		
Repeatability (typical / maximum)	dB	±0,01 / ± 0,03		
Switching time	ms	65 + 10 / channel		
Lifetime (cycles)	-	> 10		
Connector type	-	E2000 / APC		
Stability (in whole temperature range)	dB	± 0,2		
Stability (in temp. band of ±3 °C)	dB	± 0,05		
Operating temperature range	°C	from 0 to 40		
Power supply voltage - nominal	V	48 (DC)		
- range	V	18 - 72 (DC)		
Maximum consumption	W	5		
Typical consumption	W	2		
Control interface	-	RS232 , RS485		
Weight (without holders)	kg	3,00	3,10	3,25
Housing	-	MLS 80-2U-03 (2U chassis with holders for 19" and 21" rail spacing)		

M L S 9 0 - p q - m n a x b cc ddd/eee

specifies a category

p= O - for optical O-series switches
p= P - for optical P-series switches
p= S - for optical S-series switches

specifies a fiber type of built-in device

q=1 - for MM
q=2 - for SM

specifies the housing

a=A - 1 LGX a=I - 9 LGX
a=B - 2 LGX a=J - 10 LGX
a=C - 3 LGX a=K - 11 LGX
a=D - 4 LGX a=L - 12 LGX
a=E - 5 LGX a=1 1U rack 19/21"
a=F - 6 LGX a=2 2U rack 19/21"
a=G - 7 LGX a=3 3U rack 19/21"
a=H - 8 LGX a=4 4U rack 19/21"

specifies the type of a power supply required

n=D - DC 48V
n=N - DC 5V

a= directly specifies number of optical inputs

b= directly specifies number of optical outputs

cc= optionally directly specifies type of optical connectors (default type is E2000)

ddd/eee= optionally directly specifies the voltage level and wattage of a built-in subsidiary power supply output

Fiber Optic Products



MONITORING LINE SYSTEM

Optical Line Simulator



Optical Line Simulator

Type: **MLS 111**

MLS 111



Brief characteristics :

- A mobile equipment of optical time domain reflectometers.
- All the simulator is built in a plastic case.
- A set of optical and mechanical devices which doesn't need any power supply.
- Easy control by rotary knobs.
- The central part of the optical line simulator is a coil with 6 km of optical single-mode fiber wound which is divided into four sections of approximately 1500 m each.
- There are various disturbing or stressing elements inserted between sections.
- Some of the stressing elements simulate constant events, some elements offer variable stressing of the fiber. Latters are controllable by knobs at the front panel.



Application :

- For easy demonstration of OTDR facilities
- Basic testing of OTDRs
- A teaching instrument in fiber optic telecommunications

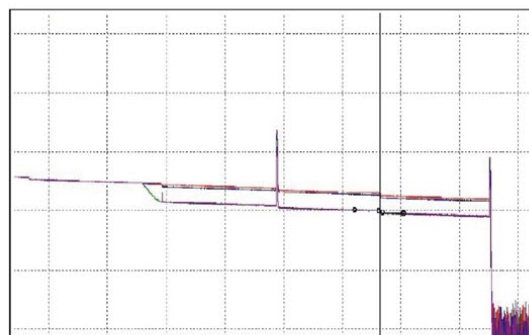

Type: **MLS 111**

MLS 111

Technical specifications

MLS 111 - Optical Line Simulator		
Fiber // connector type	μm	SM, 9/125 // SC/APC
Operating temperature range	°C	from 0 to 40
Case dimensions (w x h x d)	mm	500 x 385 x 200
Weight	kg	10
Optical line details		
Total functioned line length	m	6260 +/- 5%
Total line insertion loss	dB	< 2,3
4x CA - constant attenuation section		
- length of section	m	1500 +/- 10
- max. attenuation	dB/km	0,3
CNRSE - constant non reflecting step event		
- minimum/maximum insertion loss	dB	0,05 / ,15
VDA - section of variable distributed attenuation		
- length	m	250 +/- 20%
- reference condition	dB/km	0,3
- maximum attenuation degradation	dB/km	4 **
NNRSE - near non reflecting step event		
- position 0: insertion loss	dB	0
- position 1: minimum/maximum insertion loss	dB	0,15 / 0,3
- event loss repeatability (20 000 cycles)	dB	+/- 0,05
VNRSE - variable non reflecting step event		
- switch 2a or switch 2b, insertion loss	dB	0
- switch 2a: minimum/maximum insertion loss	dB	0,15 / 0,3
- switch 2b: minimum/maximum insertion loss	dB	0,5 / 2,0
CRSE - constant reflecting step event		
- minimum/maximum insertion loss	dB	0,1 / 0,3
- minimum/maximum return loss	dB	40 / 55
BC - break/cut		
- position connected, typical insertion loss	dB	0,3
- position disconnected, insertion loss	dB	∞
ER - end reflector		
- minimum/maximum return loss	dB	14 / 40

* if non-stressed in VDA, NNRSE or VNRSE

** Attenuation is preset to value in the range of 0..16dB/km

Fiber Optic Products

MONITORING LINE SYSTEM



Series:

MLS111-01

Optical Line Simulator



Brief characteristics :

- A mobile equipment to demonstrate functionality of optical time domain reflectometers.
- All simulators are built in a plastic case.
- A set of optical and mechanical devices which don't need any power supply.
- Easy control by rotary knobs.
- There are various disturbing or stressing elements inserted between sections.
- Some of the stressing elements simulate stable events, some elements offer variable stress exerted on the fiber which are controllable by knobs on the front panel.



Application :

- For easy demonstration of OTDR capabilities
- Basic testing of OTDRs
- A teaching instrument in fiber optic telecommunications

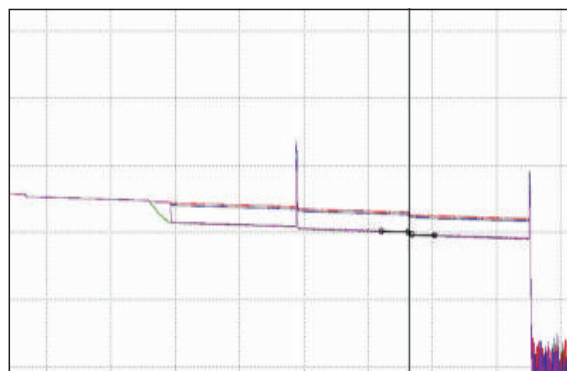

Fiber Optic Products

MLS111-01 Optical Line Simulator

Optical line demonstrators

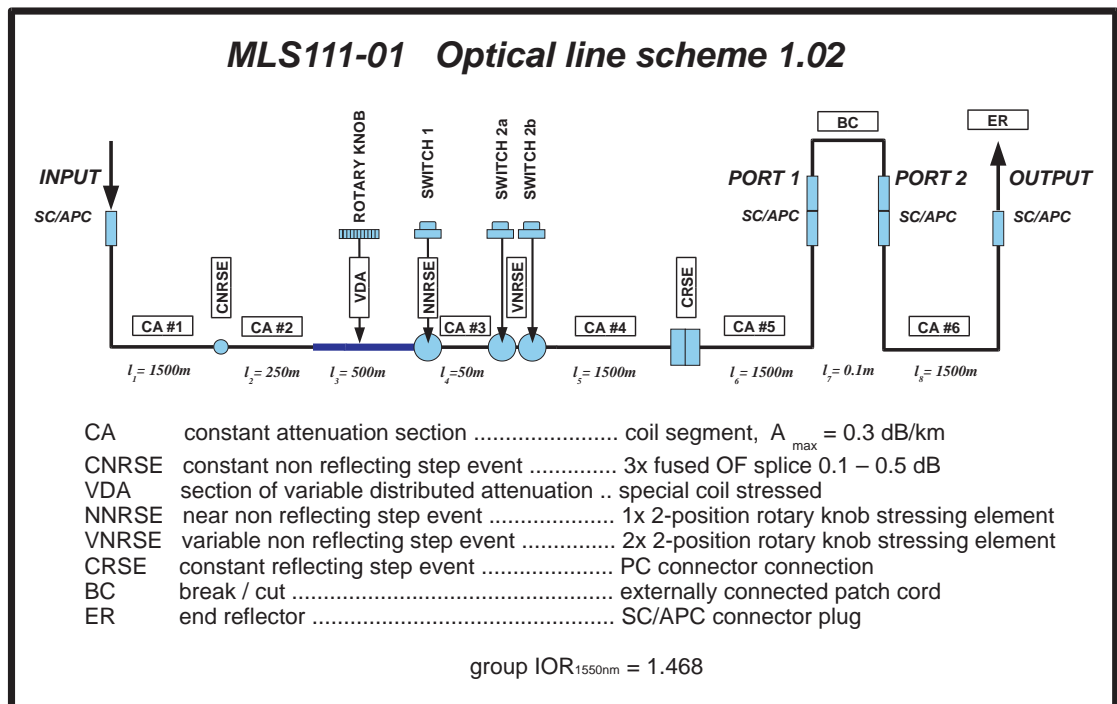
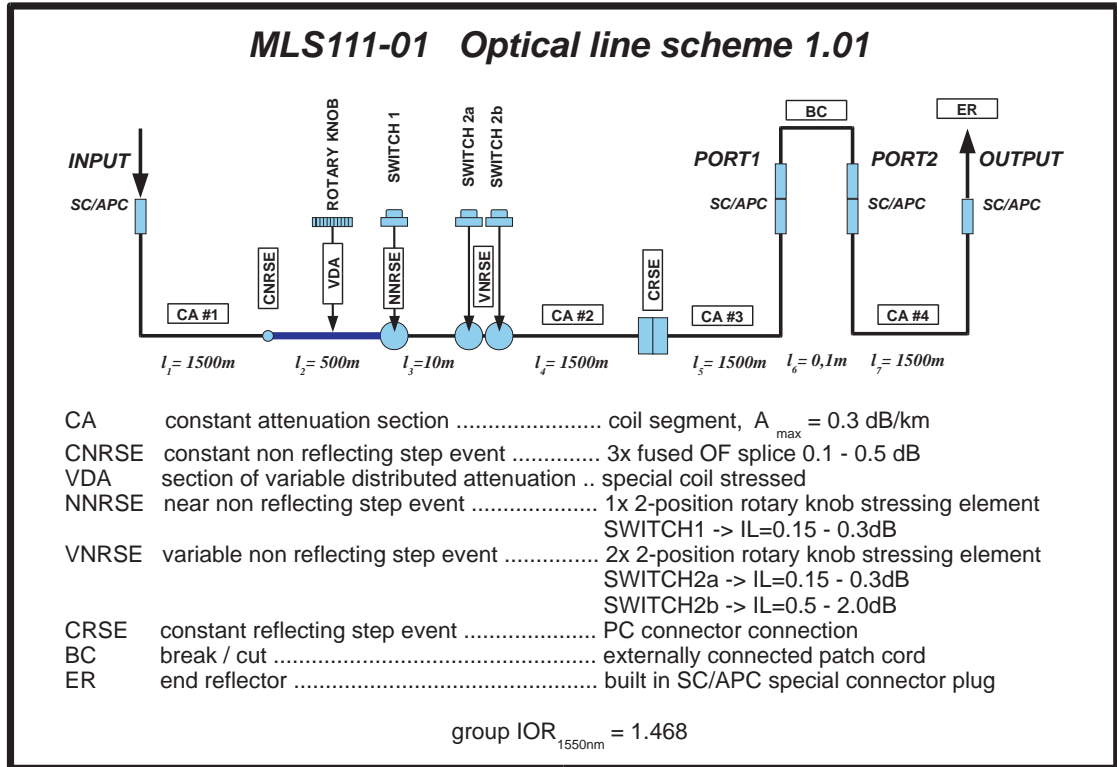

Fiber Optic Products

MONITORING LINE SYSTEM



Series:

MLS112-02

Passive Optical Network Simulator



Brief characteristics :

- A mobile equipment to demonstrate functionality of optical time domain reflectometers.
- The simulator is built in a plastic case.
- A set of optical devices which don't need any power supply.
- There are two independent Passive Optical Networks (PON) inside.
- There are macrobends of $IL=2.5\text{dB}\pm 1\text{dB}$ @ 1550nm on some traces.
- Splitters with higher number of ports are represented by splitters with low number of ports as well as attenuation splices.



Application :

- For easy demonstration of OTDR capabilities
- Basic testing of Passive Optical Networks
- A teaching instrument in fiber optic telecommunications

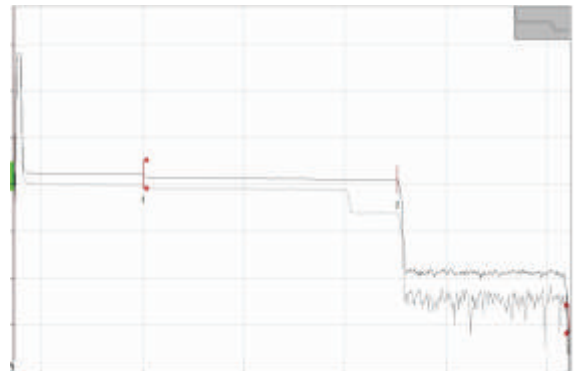

Fiber Optic Products

MLS112-02

Optical Line Simulator

Optical line demonstrator

Actual scheme

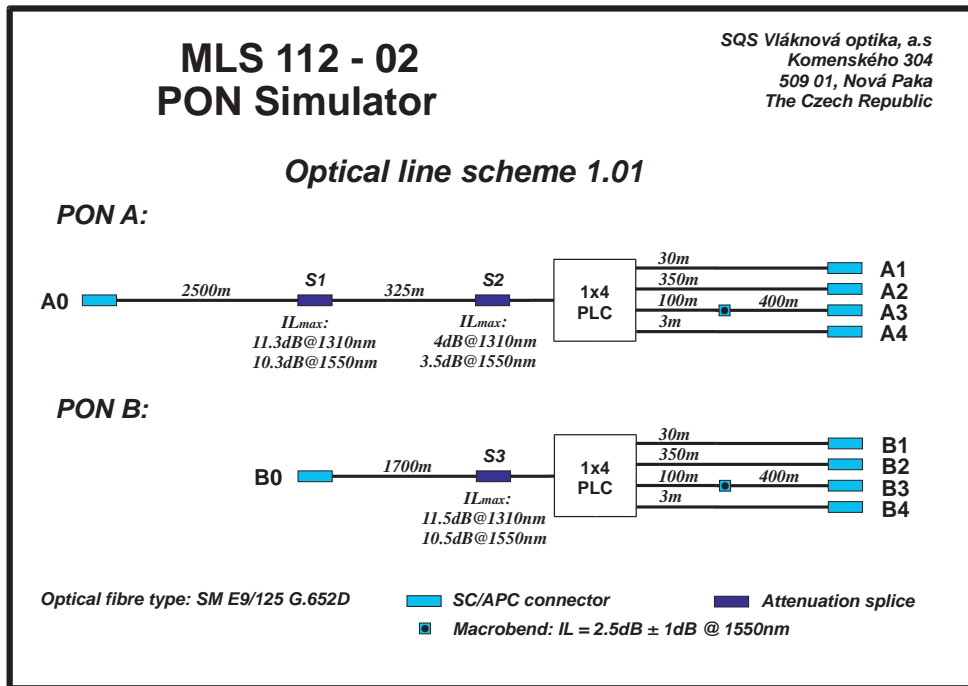

Representing following functional scheme

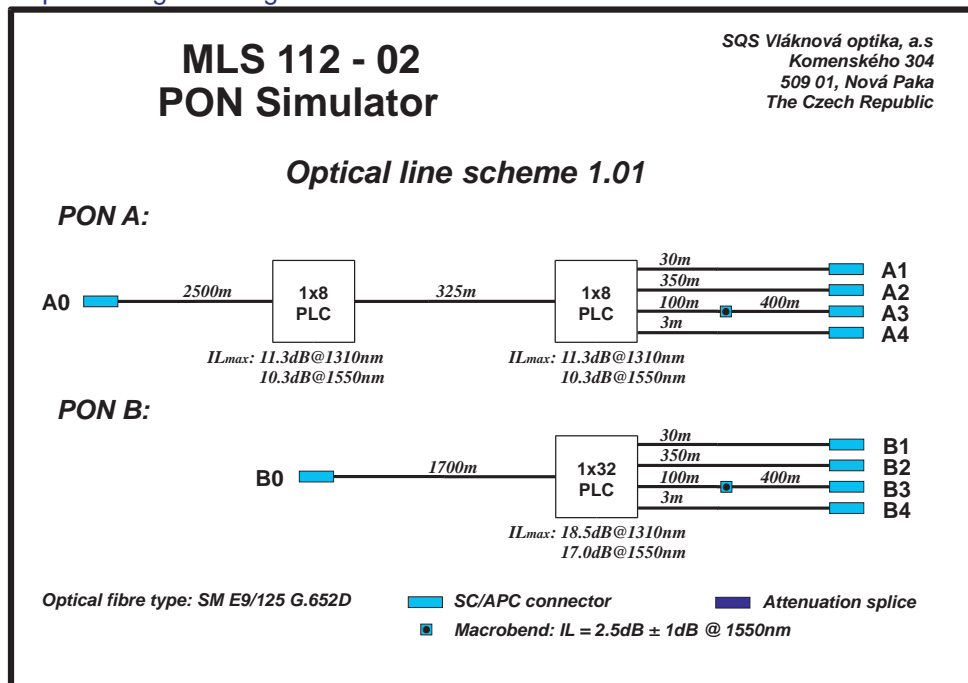

Fiber Optic Products

MONITORING LINE SYSTEM



Series:

MLS113-02

Simulator Box



Brief characteristics :

- A mobile equipment to demonstrate functionality of optical time domain reflectometers.
- The simulator is built in a plastic case.
- A set of optical devices which don't need any power supply.
- The optical trace is made-up of 2km long sections.
- There is macrobend of $IL=0.6dB\pm 0.3dB$ @1550nm on the trace.
- There is attenuation splice of $IL=0.8dB\pm 0.3dB$ @1310nm on the trace.



Application :

- For easy demonstration of OTDR capabilities
- Basic testing of OTDRs
- A teaching instrument in fiber optic telecommunications

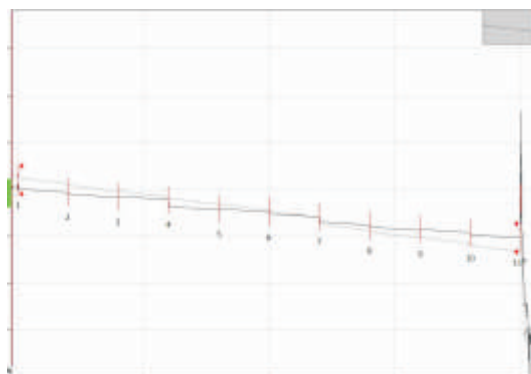

Fiber Optic Products

MLS113-02

Simulator Box

Optical line demonstrator

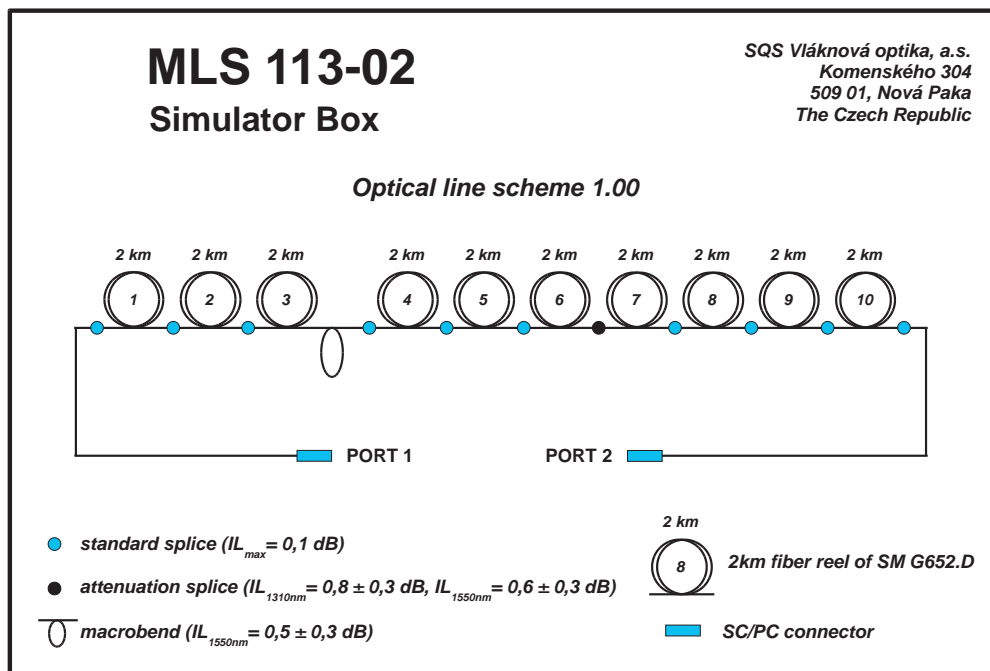

Fiber Optic Products



MONITORING LINE SYSTEM



NIR MEASURING SET

NIR MEASURING SET

Brief characteristics :

- Insertion loss precise measurement in near infrared fiber optics;
- Measurement in all standard CWDM channels;
- HW based on units of the modular SQS Monitoring Line System;
- 18 laser diode sources of wavelength range 1270, 1290, 1310 .. 1610 nm;
- 1x32 planar splitter used as a coupler;
- 1x2 (95 / 5 %) splitter used for reference level;
- 34 optical inputs with simultaneous sampling;
- Measuring with reference level and cut-back method available;
- Dynamic range of 42 dB;
- Optical ports with E2000/APC connectors;
- Optionally provided with software for PC;
- Measuring software customized on demand;
- Easy serial bus protocol offers software facilities of an open system.

Application :

- Provides quick automated spectral measurements;
- Suitable for final tests in serial production of splitters, add&drop modules;
- WDM and CWDM units, isolators and other passive fiber optics components.

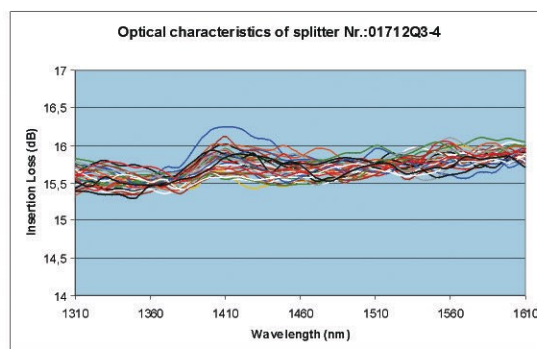

NIR MEASURING SET

NIR MEASURING SET

TECHNICAL SPECIFICATIONS

NIR MEASURING SET		
Laser sources		
Number of CWDM channels	-	18
Wavelength tolerance (from the nominal CWDM channel WL)	nm	-1 / +4
Output optical level (each laser diode output)	dBm	0
Minimum output optical level (1 active laser, coupler output)	dBm	-17
Minimum output optical level (1 active laser, splitter output 95%)	dBm	-18
Laser diode type	-	DFB
Output power stability (24 hours, T = const.)	dB	±0,01
Output power stability (T = 0 ÷ 40 °C)	dB	±0,1
Receivers		
Number of optical inputs	-	34
Sensor type	-	PIN
Wavelength range	nm	1100 ÷ 1650
Input level range	dBm	-60 ÷ 0
Detected level stability (T = 0 ÷ 40 °C)	dB	±0,1
Common parameters		
Optical connectors	-	E2000 / APC
Operating temperature range	°C	0 ÷ 40
Power supply voltage	V	230 AC
Maximum consumption (start up / typical)	W	80 / 20
Dimensions (height x width x depth)	cm	125 x 65 x 60
Weight (app.)	kg	30

Fiber Optic Products

MONITORING LINE SYSTEM



FIBER OPTIC COILS



Brief characteristics :

- Fiber optic coils on spool or air up to 5km in length
- Various types of optical fibers (G652.D, G657.A, OM2, OM3 ...) available
- Winding of 250um buffered fibers
- Checking of optical and mechanical parameters
- Availability of connectors at the ends of fiber



Application :

- Launch Test Cables (LTC) used for optical measurements
- Simulators (PON, OTDR, ...) for demonstration of OTDR capabilities
- Basic testing of OTDRs
- Fiber optic gyroscope

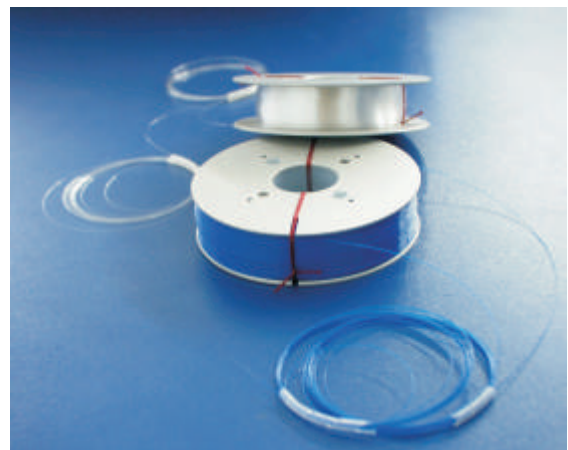

Fiber Optic Products

FIBER OPTIC COILS

Parameters

Common	
Fiber type	250um buffered only
Fiber length available	up to 5km
Fiber length accuracy	+/- 10m
Output pigtail length	as requested
Coil diameter - minimum inside diameter - maximum outside diameter	50 mm 200 mm
Optional	
Optical connector	SC, FC, E2000, LC, ST, DIN, MU
Physical contact	PC, APC
Maximum insertion loss	0.5 dB *
Reflectance - maximum, fiber SM, PC/APC - maximum, fiber MM 50, PC - maximum, fiber MM62.5, PC	-50 / -60 dB * -45 dB * -50 dB *
Fiber SM 9/125/250	
Attenuation of the G625.D fiber due to coiling - maximum @1310nm - maximum @1550nm	0.37 dB/km 0.25 dB/km
Bending detection	trace discontinuity < 0.02 dB
Fiber MM 50/125/250	
Attenuation of the OM3 fiber due to coiling - maximum @850nm - maximum @1300nm	3.0 dB/km 1.0 dB/km
Bending detection	trace discontinuity < 0.01 dB
Fiber MM62.5/125/250	
Attenuation of the OM1 fiber due to coiling - maximum @850nm - maximum @1300nm	3.2 dB/km 1.0 dB/km
Bending detection	trace discontinuity < 0.01 dB

Note: * bidirectional OTDR test

MONITORING LINE SYSTEM



TECHNICAL SPECIFICATIONS

MLS - HW units

Table of Contents

Optical transmitters	4
MLS 30T Optical transmitter unit - LD optical source, controlled	4
Brief characteristics.....	4
MLS optical transmitter units – parameters	4
Optical receivers.....	5
MLS 30R Receiver unit - InGaAs PIN optical power meter.....	5
Optical receiver units - parameters	5
Combined transmitter/receiver units.....	6
MLS 30A Autonomous transmitter/receiver unit.....	6
Brief characteristics.....	6
Part T – transmitter.....	6
Part R – receiver.....	6
MLS 30B *) Combined transmitter/receiver unit.....	7
Brief characteristics.....	7
Part T – transmitter.....	7
Part R – receiver.....	7
Combined transmitter/receiver units - parameters.....	8
Power supply units.....	9
MLS 40B Power supply units.....	9
Brief characteristics.....	9
MLS 40-B - parameters.....	10
Communicators.....	11
MLS 50A Communication unit.....	11
Brief characteristics.....	11
MLS 50B Autonomous communication unit.....	11
Brief characteristic.....	11
Communicator units - parameters.....	12
WDM units.....	13
MLS 60-V2-0A-2E	13
MLS 60-W2-0A-2E	14
MLS 60-W2-1A-2E	15
MLS 60-W2-2A-2E	16
MLS 60-V4-0A-2E	17
MLS 60-W4-0A-2E	18
MLS 60-W4-3A-2E	19
MLS 60-W4-4A-2E	20
MLS 60-C8-AH-2E	21
MLS 60-C0-AH-2E	22
MLS 60-L1-0A-2E 1310-1550	23
MLS 60-L1-1A-2E 1310-1550	24
Circulators.....	25
MLS 70-C0-3SD-2E.....	25
MLS 70-C0-3DD-2E.....	25
Splitters.....	26
MLS 70-S2-1A2-2E (1x2).....	26
MLS 70-S2-1A4-2E (1x4)	26
MLS 70-S4-1A2-2E (1x2).....	27
MLS 70-S4-1A4-2E (1x4)	27
MLS 70-S4-1A8-2E (1x8)	28
LGX style chassis.....	29
MLS 80-2U-01.....	29
MLS 80-2U-02.....	30
MLS 80-4U-01.....	31
MLS 80-3U-01.....	32

LGX compatible boxes.....	34
Boxes 1LGX / 3U.....	34
Box 2LGX / 3U.....	35
Box 4LGX / 3U.....	35
Optical switches.....	36
MLS 90-O Optical switches 1x2 and 1x4.....	36
Brief characteristics.....	36
MLS90-P Optical switches 1x4 , 1x8.....	36
Brief characteristics.....	36
MLS 90-O series - parameters.....	37
MLS 90-P series - parameters.....	38
MLS 90-S Optical switches 1x24, 1x32 and 1x48.....	39
Brief characteristics.....	39
Reflectometers.....	40
MLS 400 OTDR.....	40
Brief characteristics.....	40
Measurement modules.....	40
OTDR units – parameters.....	40
Type designations.....	41
Combined autonomous units.....	41
Transmitters.....	41
Transmitters – alternative extended code.....	42
Receivers.....	43
Power supply units.....	43
Communicators.....	44
WDM units.....	44
CWDM and ADD&DROP units.....	45
Splitter units.....	46
Splitter units – extended code for multiple units.....	47
Circulators.....	48
LGX Style Chassis.....	48
Optical switches.....	49
ECCN designation for MLS.....	50

Optical transmitters

MLS 30T Optical transmitter unit - LD optical source, controlled

Brief characteristics

- Optical source with increased, actively controlled power stabilisation, intended for long term stand-alone operation in a remote or local station with an ability of being under full direct performance control;
- Laser diode operating in CW mode, optionally in 1310nm, 1550nm or 1625nm wavebands;
- Lasers type:
 - Fabry-Perot 1310, 1550 +/- 20nm
 - DFB 1615, 1625 +/-5nm
 - DFB 1271, 1291, ..., 1611nm +/- 5nm (CWDM Series)
- Elimination of back reflections influence on the LD operation – LD stability independent on back reflection and interference changes in the line under monitoring;
- Remote or local station control via RS 485 interface;
- Without display, optical power level controlled by local PC or by server (via MLS 50B);
- All MLS 50 variants compatible;
- Power supply: 48 V DC;
- 1 laser diode optionally provided with 1x2 or 1x4 splitter.
- Housing: long LGX 3U/2 module.

MLS optical transmitter units – parameters

MLS unit		MLS 30-Tx-D F1310-D1610-50	MLS 30-Tx-D F1550-25-25-25	MLS 30-Tx-D D1550-10
LD type		Fabry-Perot , DFB 1311 +/- 20nm 1611 +/- 5nm	Fabry-Perot 1550 +/- 20nm	DFB 1551 +/- 5nm
Fibre//connector type	µm	SM, 9/125 // E2000/APC		
Optical output level	dBm	> 0 and -3 (2x)	> -6 (4x)	> -0,5 and > -10
Number of optical ports	-	3	4	2
Number of splitters		1	1	1
CW output level stability 24 hrs, constant temperature operating temperature range	dB dB	±0,01 ±0,1		
Operating temperature range	°C	from 0 to 40		
Power supply nominal voltage voltage range	V V	48 (DC) 18 - 72 (DC)		
Maximum consumption I _{max}	mA	150		
Typical consumption I _{typ}	mA	70		
Housing	-	LGX 3U/2		
Weight	kg	0,75		

Note: The multi-laser transmitters combining various laser types and wave lengths and the transmitters equipped with specific ratio splitters are coded according to the table “Transmitters - alternative extended code “ in the chapter “Type designations”.

Optical receivers

MLS 30R Receiver unit - InGaAs PIN optical power meter

Brief characteristics

- High resolution, fully remote controlled optical power meter (dBm, dB) with quick time response, equipped with an internal operational memory and an active stabilisation circuit
- Intended for long term stand-alone operation in a remote or local station;
- Wavelength range: 1100 - 1650 nm;
- Internal operating memory;
- Remote or local station control via the RS 485 interface;
- Without display, the optical power level read by a local PC or by a server (via MLS 50B);
- Two adjustable signalling levels (warning, alarm) for each channel, panel signalling;
- All MLS 50 variants compatible;
- Power supply: 48V DC;
- 1, 2 or 4 channels;
- Housing: long LGX 3U/2 module.

Optical receiver units - parameters

MLS unit		MLS 30-Rx-1-D1	MLS 30-Rx-2-D1	MLS 30-Rx-t-D2
Number of PIN diodes		1	2	from 1 to 4
Wavelength range	nm	1100 - 1650		
PIN type		InGaAs		
Calibrating wavelength	nm	1310 for x=1, 1550 for x=2, 1610 for x=3		
Opt. coupling type		contact (pig-tail PIN)		contactless (E2000 + PIN)
Input opt. level range	dBm	from -60 to 0		
Resolution	dB	0,01		
Fiber	µm	SM		SM or MM
Connector		E2000/APC		
Linearity in range of input level $\pm 2,5$ dB all input level range	dB dB	$\pm 0,05$ $\pm 0,30$		
Stability in whole operating temperature range	dB	$\pm 0,1$		
Response time var. 0,1 dB in all range	ms	300		
Operating temperature range	°C	from 0 to 40		
Power supply nominal voltage voltage range	V V	48 (DC) 18 - 72 (DC)		
Maximum consumption I_{max}	mA	35 for y=2 200 for y=1	35 for y=2 200 for y=1	35
Typical consumption I_{typ}	mA	25 for y=2 60 for y=1	25 for y=2 70 for y=1	25
Housing	-	LGX 3U/2		
Weight	kg	0,60	0,66	x

Combined transmitter/receiver units

MLS 30A Autonomous transmitter/receiver unit

Brief characteristics

- Combined T/R unit with a transmitter and a receiver in one module with full controlling and signalling local equipment;
- Front panel display and press-button keyboard, panel signalling;
- Remote or on-site control of T/R parts via the RS 485 interface;
- All MLS 50 variants compatible;
- Subsidiary voltage output: 5 V DC/300mA ;
- Two independently adjustable signalling levels (warning, alarm) for each channel, panel signalling;
- Local alarm signalling with possibility of external signalling attachment (relay output);
- 1 laser diode optionally provided with the 1x2 splitter
- 1 or 2 input channels;
- Power supply: 230 V AC or 48V DC;
- Housing: long LGX 3U/4 module.

Part T – transmitter

- Laser diode optical source with increased, actively controlled power stabilisation, intended for long term stand-alone operation in remote or local station, full direct performance control, CW operation mode, wavelength optionally in 1310 nm, 1550 nm or 1625 nm wavebands;
- Elimination of line back reflection influence on the LD operation – LD stability independent on back reflection and interference changes in the line under monitoring.

Part R – receiver

- High resolution, fully remote controlled optical power meter (dBm, dB) with quick time response, equipped with an internal operating memory and active stabilisation, intended for long term stand-alone operation in a remote or local station, wavelength range: from 1100 to 1650 nm;
- As a photo detector utilized InGaAs PIN diode.

MLS 30B *) **Combined transmitter/receiver unit**

Brief characteristics

- Combined T/R unit with a transmitter and a receiver in one module;
- Without display;
- LED front panel communication indication;
- Remote or on-site control of T/R parts via RS 485 interface;
- All MLS 50 variants compatible;
- Two independently adjustable signalling levels (warning, alarm) for each channel, panel signalling;
- Power supply: 48V DC;
- Subsidiary voltage output: 5 V DC/300mA ;
- 1 laser diode optionally provided with the 1x2 splitter
- 1 or 2 input channels;
- Housing: long LGX 3U/2 module.

Part T – transmitter

- Laser diode optical source with increased and actively controlled power stabilisation, intended for long term operation in a remote or local station, full direct performance control, CW operation mode, wavelength optionally in 1310 nm, 1550 nm or 1625 nm wavebands;
- Elimination of line back reflection influence on the LD operation – LD stability independent on back reflection and interference changes in the line under monitoring.

Part R – receiver

- High resolution, fully remote controlled optical power meter (dBm, dB) with quick time response, equipped with internal operating memory and active stabilisation, intended for long term operation in a remote or local station, wavelength range: from 1100 to 1650 nm;
- As a photo detector utilized InGaAs PIN diode.

*) in development

Combined transmitter/receiver units - parameters

MLS unit		MLS 30-Ax -1N1-A	MLS 30-Ax - 1S2-A	MLS 30-Ax -1N1-D	MLS 30-Ax - 1S2-D	MLS 30-Bx -1N1-D *)	MLS 30-Bx -1S2-D *)
Part T - transmitter							
LD type		Fabry-Perot 1310 +/- 20 nm Fabry-Perot 1550 +/- 20 nm DFB 1615, 1625 +/- 5 nm DFB 1271, 1291, ..., 1611nm +/-5 nm (CWDM series)					
Fiber // connector type	µm	SM, 9/125 // E2000/APC					
Output optical level	dBm	> 0	> -3	> 0	> -3	> 0	> -3
CW output level stability 24 hrs, constant temperature operating temperature range	dB dB	±0,01 ±0,1					
Part R - receiver							
PIN type		InGaAs					
Number of PIN diodes		1	2	1	2	1	2
Wavelength range	nm	1100 - 1650					
Input level range	dBm	from -60 to 0					
Resolution	dB	0,01					
Linearity for input level range of ±2,5 dB whole input level range	dB dB	±0,05 ±0,30					
Stability operating temperature range	dB	±0,1					
Response change 0,1 dB, in whole range	ms	300					
Common parameters							
Operating temperature range	°C	from 0 to 40					
Subsidiary voltage output	V/ mA	5/300	5/300	5/300	5/300	NA	NA
Power supply Nominal voltage voltage range Maximum consumption I _{max} Typical consumption I _{typ}	V V mA mA	230 (AC) 230 (AC) 85 55	230 (AC) 230 (AC) 85 55	48 (DC) 36 - 72 350 140	48 (DC) 36 - 72 350 140	48 (DC) 18 - 72 250 100	48 (DC) 18 - 72 250 100
Housing	-	LGX 3U/4				LGX 3U/2	
Weight	kg	1,66				x	

*) in development

Power supply units

MLS 40B Power supply units

Brief characteristics

- Switching power supply series gives you consistent, reliable, switched DC power;
- The models accept universal 100/ 230 VAC input voltage for worldwide use and provide multiple output terminals for easy wiring;
- Switching power supply series enables operation of the other active MLS units, transforming electric power usually from 230 VAC to 48 VDC which is designated as the MLS power distributing voltage;
- The units provides fully floating DC voltages suitable for other electrically powered MLS units
 - basic output DC voltage: 48V
 - supplemental standby output DC voltage: 5V
 - supplemental fan output DC voltage: 12V
- Total maximum output power is specified in the range from 40 to 150 W;
- Compliant with international safety and EMI standards. (All units are of full CE compliance, EN61000-3-2 included);
- Over-current, over-voltage and over-temperature protection;
- Available RoHS compliant
- Available with convection cooling, i.e. no internal fan;
- Housing: long LGX 3/2 module.

250 W on main channel with forced air

Features include: Power Factor (>0.99)
operating temperature 0°C to +50°C at full load,

MLS 40-B - parameters

MLS unit		MLS 40-B5-A 60W	MLS 40-B4-A 60W	MLS 40-B7-A 150W
Input DC voltage range	V	from 120 to 300		
Input AC voltage range	V	from 85 to 264		
Input AC frequency range	Hz	from 47 to 440		from 47 to 63
Maximum input surge current - pro 115 VAC - pro 230 VAC - pro 264 VAC	A	18 36 -		- - 40
Maximum input current (ef.)	A	1,5 (pro 115 VAC)		2,78 (pro 120 VAC) 1,36 (pro 230 VAC)
Fuse	A	T3,15 / 250 VAC		T6,3 AH / 250VAC
Number of output connectors	-	4x MIC334		3x MIC334 1x MIC338
Output DC voltage 1	V	48		
Maximum power	W	60		150
Overload protection	-	YES		
Temperature stability	% / K	0,04		0,02
Output DC voltage 2	V	5	-	5
Maximum power	W	8	-	5
Overload protection	-	YES	-	YES
Fuse	A	1,6	-	NA
output DC voltage 3	V	-	-	12
Maximum power	W	-	-	4
Overload protection	-	-	-	YES
Operating temperature range	°C	from 0 to 40		
Storage temperature	°C	from -40 to 85		
Housing	-	LGX 3U/2		
Built-in ventilator	-	YES		NA
Weight	kg	0,9	0,8	1,0

Communicators

MLS 50A Communication unit

Brief characteristics

- Communication interface between Ethernet LAN or WAN and a serial RS485 bus;
- TCP/IP protocols at the Ethernet side;
- MLS serial protocol at the side of the serial bus with up to 32 MLS active units;
- Without display.
- Without front panel setting of controlled measuring units;
- MLS 30 alarm status monitoring and its processing towards to the master PC or server;
- Integrated firewall ensures a secure communication LAN / WAN channel;
- Communication indicated on LED front panel;
- WEB interface for MLS 50A unit remote configuration;
- Power supply: 48 V DC or 5 V DC;
- Housing: 1 communication unit in long 1LGX module.

MLS 50B Autonomous communication unit

Brief characteristic

- Communication interface between Ethernet LAN or WAN and serial RS485 bus;
- TCP/IP protocols at the Ethernet side;
- MLS serial protocol at the side of the serial bus with up to 32 MLS active units;
- Local station controlling and all MLS 30 unit variants management;
- Front panel display for setting and optical power reading on controlled MLS 30 measuring units;
- MLS 30 alarm status monitoring and its processing towards to the master PC or server;
- Integrated firewall ensures a secure communication LAN / WAN channel;
- Communication indicated on LED front panel;
- WEB interface for MLS 50A unit remote configuration;
- Local alarm signalling with possibility of external signalling attachment (relay output);
- Local configuration of the MLS 50B unit;
- Remote configuration of the MLS 50B unit via a WEB interface;
- Power supply: 230 V AC or 48V DC;
- Optional subsidiary voltage output 5 V DC/3 A;
- Subsidiary voltage output 48 V DC/1 A (var A-D);
- Housing: 1 communication unit in long 4LGX module.

Communicator units - parameters

MLS unit		MLS 50-A0-N	MLS 50-A0-D	MLS 50B1-D	MLS 50-B1-A	MLS 50-B5-A
Display		NA		YES		
Front panel keyboard		NA		YES		
Interface RS 485		1		2		
Interface MT-RJ		1				
Local alarm signal		NA	NA	YES	YES	YES
Subsidiary voltage	V/A	NA	NA	5/2,5	5/2,5	5/2 48/0,4
Power supply						
nominal voltage	V	5 (DC)	48 (DC)	48 (DC)	230 (AC)	230 (AC)
voltage range	V		18 - 72 (DC)	36 - 72 (DC)		
maximum consumption I_{max}	mA	80	20	85	50	50
typical consumption I_{typ}	mA	75	10	80	45	45
Operating temperature range	°C	from 0 to 40				
Housing	-	LGX 3U/1		LGX 3U/4		
Weight	kg	0,34		1,26		

WDM units

MLS 60-V2-0A-2E

MLS 60-V2-0A-2E		
Working wavelength band	nm	1295 - 1325
Monitoring wavelength band	nm	1535 - 1565
Fiber // connector type	μm	SM, 9/125 // E2000/APC
Number of WDM devices in the module	-	1
Number of optical ports	-	3
Front panel marking - common port - working band port - monitoring band port	-	13/15-1 1310-1 1550-1
Maximum/typical insertion loss between optical ports 13/15-1 : 1310-1 13/15-1 : 1550-1	dB	1,0 / 0,6 1,0 / 0,6
Minimum/typical isolation between ports 13/15-1:1310-1 for @1550nm	dB	16 / 20
Minimum/typical isolation between ports 13/15-1:1550-1 for @1310nm	dB	16 / 20
Directivity	dB	typ. 50
Return loss (RL)	dB	> 55
Operating temperature range	°C	from 0 to 40
Temperature stability	dB	< 0,2
Housing	-	LGX 3U/1
Weight	kg	0,26

MLS 60-W2-0A-2E

MLS 60-W2-0A-2E		
Working wavelength band	nm	1295 - 1325
Monitoring wavelength band	nm	1535 - 1565
Fiber // connector type	μm	SM, 9/125 // E2000/APC
Number of WDM devices in the module	-	2
Number of optical ports	-	6
Front panel marking - common ports - working band ports - monitoring band ports	-	13/15-1 , 13/15-2 1310-1 , 1310-2 1550-1 , 1550-2
Maximum/typical insertion loss between optical ports 13/15-1 : 1310-1 , 13/15-2 : 1310-2 13/15-1 : 1550-1 , 13/15-2 : 1550-2	dB	1,0 / 0,6 1,0 / 0,6
Minimum/typical isolation between ports 13/15-1:1310-1 , 13/15-2:1310-2 for @1550nm	dB	16 / 20
Minimum/typical isolation between ports 13/15-1:1550-1 , 13/15-2:1550-2 for @1310nm	dB	16 / 20
Directivity	dB	typ. 50
Return loss (RL)	dB	> 55
Operating temperature range	°C	from 0 to 40
Temperature stability	dB	< 0,2
Housing	-	LGX 3U/1
Weight	kg	0,29

MLS 60-W2-1A-2E

MLS 60-W2-1A-2E		
Working wavelength band	nm	1295 - 1325
Monitoring wavelength band	nm	1535 - 1565
Fiber // connector type	μm	SM, 9/125 // E2000/APC
Number of WDM devices in the module	-	2
Number of optical ports	-	4
Front panel marking - common ports - monitoring band ports	-	13/15-1 , 13/15-2 1550-1 , 1550-2
Maximum/typical insertion loss between optical ports 13/15-1 : 13/15-2 13/15-1 : 1550-1 , 13/15-2 : 1550-2	dB	1,4 / 1,0 1,0 / 0,6
Minimum/typical isolation between ports 13/15-1:13/15-2 for @1550nm	dB	32 / 40
Minimum/typical isolation between ports 13/15-1:1550-1 , 13/15-2:1550-2 for @1310nm	dB	16 / 20
Directivity	dB	typ. 50
Return loss (RL)	dB	> 55
Operating temperature range	°C	from 0 to 40
Temperature stability	dB	< 0,2
Housing	-	LGX 3U/1
Weight	kg	0,27

MLS 60-W2-2A-2E

MLS 60-W2-2A-2E		
Working wavelength band	nm	1295 - 1325
Monitoring wavelength band	nm	1535 - 1565
Fiber // connector type	μm	SM, 9/125 // E2000/APC
Number of WDM devices in the module	-	2
Number of optical ports	-	4
Front panel marking - common ports - working band ports	-	13/15-1 , 13/15-2 1310-1 , 1310-2
Maximum/typical insertion loss between optical ports 13/15-1 : 13/15-2 13/15-1 : 1310-1 , 13/15-2 : 1310-2	dB	1,4 / 1,0 1,0 / 0,6
Minimum/typical isolation between ports 13/15-1:13/15-2 for @1310nm	dB	32 / 40
Minimum/typical isolation between ports 13/15-1:1310-1 , 13/15-2:1310-2 for @1550nm	dB	16 / 20
Directivity	dB	typ. 50
Return loss (RL)	dB	> 55
Operating temperature range	°C	from 0 to 40
Temperature stability	dB	< 0,2
Housing	-	LGX 3U/1
Weight	kg	0,27

MLS 60-V4-0A-2E

MLS 60-V4-0A-2E		
Working wavelength bands	nm	1260 - 1360 1480 - 1580
Monitoring wavelength band	nm	1610 - 1650
Fiber // connector type	μm	SM, 9/125 // E2000/APC
Number of WDM devices in the module	-	1
Number of optical ports	-	3
Front panel marking - common port - working band port - monitoring band port	-	13/15/16-1 13/15-1 1625-1
Maximum/typical insertion loss between optical ports 13/15/16-1 : 13/15-1 13/15/16-1 : 1625-1	dB	1,6 / 1,0 1,5 / 0,9
Minimum/typical isolation between ports 13/15/16-1:1625-1 for @1310 and @1550nm	dB	22 / 25
Minimum isolation between ports 13/15/16-1:13/15-1 for @1610nm for @1620nm for @1630nm for @1640nm	dB	25 35 40 45
Directivity	dB	typ. 50
Return loss (RL)	dB	> 55
Operating temperature range	°C	from 0 to 40
Temperature stability	dB	< 0,2
Housing	-	LGX 3U/1
Weight	kg	0,26

MLS 60-W4-0A-2E

MLS 60-W4-0A-2E		
Working wavelength bands	nm	1260 - 1360 1480 - 1580
Monitoring wavelength band	nm	1610 - 1650
Fiber // connector type	μm	SM, 9/125 // E2000/APC
Number of WDM devices in the module	-	2
Number of optical ports	-	6
Front panel marking - common ports - working band ports - monitoring band ports	-	13/15/16-1 , 13/15/16-2 13/15-1 , 13/15-2 1625-1 , 1625-2
Maximum/typical insertion loss between optical ports 13/15/16-1 : 13/15-1 , 13/15/16-2 : 13/15-2 13/15/16-1 : 1625-1 , 13/15/16-2 : 1625-2	dB	1,6 / 1,0 1,5 / 0,9
Minimum isolation between ports 13/15/16-1:1625-1 , 13/15/16-2:1625-2 for @1310nm and @1550nm	dB	22 / 25
Minimum/typical isolation between ports 13/15/16-1:13/15-1 , 13/15/16-2:13/15-2 for @1610nm for @1620nm for @1630nm for @1640nm	dB	25 35 40 45
Directivity	dB	typ. 50
Return loss (RL)	dB	> 55
Operating temperature range	°C	from 0 to 40
Temperature stability	dB	< 0,2
Housing	-	LGX 3U/1
Weight	kg	0,29

MLS 60-W4-3A-2E

MLS 60-W4-3A-2E		
Working wavelength bands	nm	1260 - 1360 1480 - 1580
Monitoring wavelength band	nm	1610 - 1650
Fiber // connector type	μm	SM, 9/125 // E2000/APC
Number of WDM devices in the module	-	2
Number of optical ports	-	4
Front panel marking - common ports - working band ports	-	13/15/16-1 , 13/15/16-2 13/15-1 , 13/15-2
Maximum/typical insertion loss between optical ports 13/15/16-1 : 13/15-1 , 13/15/16-2 : 13/15-2 13/15/16-1 : 13/15/16-2	dB	1,6 / 1,0 2,4 / 1,6
Minimum/typical isolation between ports 13/15/16-1:13/15/16-2 for @1310nm and @1550nm	dB	44 / 50
Minimum isolation between ports 13/15/16-1:13/15-1 , 13/15/16-2:13/15-2 for @1610nm for @1620nm for @1630nm for @1640nm	dB	25 35 40 45
Directivity	dB	typ. 60
Return loss (RL)	dB	> 55
Operating temperature range	°C	from 0 to 40
Temperature stability	dB	< 0,2
Housing	-	LGX 3U/1
Weight	kg	0,27

MLS 60-W4-4A-2E

MLS 60-W4-4A-2E		
Working wavelength bands	nm	1260 - 1360 1480 - 1580
Monitoring wavelength band	nm	1610 - 1650
Fiber // connector type	μm	SM, 9/125 // E2000/APC
Number of WDM devices in the module	-	2
Number of optical ports	-	4
Front panel marking - common ports - monitoring band ports	-	13/15/16-1 , 13/15/16-2 1625-1 , 1625-2
Maximum/typical insertion loss between optical ports 13/15/16-1 : 1625-1 , 13/15/16-2 : 1625-2 13/15/16-1 : 13/15/16-2	dB	1,5 / 0,9 2,6 / 1,8
Minimum/typical isolation between ports 13/15/16-1:1625-1 , 13/15/16-2:1625-2 for @1310nm and @1550nm	dB	22 / 25
Minimum isolation between ports 13/15/16-1:13/15/16-2 for @1610nm for @1620nm for @1630nm for @1640nm	dB	50 70 80 90
Directivity	dB	typ. 60
Return loss (RL)	dB	> 55
Operating temperature range	°C	from 0 to 40
Temperature stability	dB	< 0,2
Housing	-	LGX 3U/1
Weight	kg	0,27

MLS 60-C8-AH-2E

MLS 60-C8-AH-2E		
Working wavelength range	nm	1471/1491/1511/1531/1551/1571/1591/1611
Working WL bandwidth	nm	>13
Number of components in the module	-	1
Number of optical outlets of the module	-	9
Front panel labeling	-	COMMON, 1, 2, 3, 4, 5, 6, 7, 8
Maximum insertion loss between channels *** COMMON : 1 (2, 3 ,4 ,5 ,6, 7, 8)	dB	2,5
Isolation between adjacent channels ***	dB	> 30
Isolation between non-adjacent channels ***	dB	> 40
Directivity	dB	typ. 55
Return loss (RL) ***	dB	> 55
Polarisation dependent loss (PDL) ***	dB	< 0,17
Fiber // connector type	μm	SM, 9/125 // E2000/APC
Operating temperature range	°C	from 0 to 40
Temperature stability	dB	< 0,2
Housing	-	LGX 3U/2
Weight	kg	0,5

MLS 60-C0-AH-2E

MLS 60-C0-AH-2E		
Working wavelength range	nm	1471/1491/1511/1531/1551/1571/1591/1611
ADD&DROP channel	nm	1611
Working WL bandwidth	nm	>13
Number of components in the module	-	1
Number of optical outlets of the module	-	4
Front panel labeling	-	1611-DROP, 1611-ADD, IN, OUT
Maximum/ typ. insertion loss between channels * IN : OUT IN : 1611-DROP 1611-ADD : OUT	dB	2,0 / 1,1 2,0 / 0,9 2,0 / 0,9
Isolation between adjacent channel IN : OUT for 1611nm IN : 1611-DROP for channels 1471 to 1591 nm 1611-DROP : OUT for channels 1471 to 1591 nm 1611-ADD : 1611-DROP	dB	>30 > 30 > 30 > 40
Directivity (typ.)	dB	55
Return loss (RL) ***	dB	> 55
Polarisation dependent loss (PDL) ***	dB	< 0,17
Fiber // connector type	µm	SM, 9/125 // E2000/APC
Operating temperature range	°C	from 0 to 40
Temperature stability**	dB	< 0,2
Housing	-	LGX 3U/1
Weight	kg	0,27

* splices and connectors in the range 0 – 40 °C included

** preliminary

*** valid for all channels in the range 0 – 40 °C, splices and connectors included

MLS 60-L1-0A-2E 1310-1550

MLS 60-L1-0A-2E 1310-1550		
Working wavelength bands	nm	1290 - 1330 1530 - 1570
Fiber // connector type	μm	SM, 9/125 // E2000/APC
Number of optical ports	-	5
Front panel marking - line port - input ports - output ports	-	LINE Tx13 , Tx15 Rx13 , Rx15
Maximum/typical insertion loss between optical ports L : Rx13 for @1310nm L : Rx15 for @1550nm Tx13 : L for @1310nm Tx15 : L for @1550nm	dB	2,2 / 1,0 4,0 / 2,7 1,6 / 0,7 3,5 / 2,6
Minimum/typical isolation between ports L : Rx13 for @1550nm L : Rx15 for @1310nm L : Tx13 for @1310nm L : Tx13 for @1550nm L : Tx15 for @1310nm L : Tx15 for @1550nm Tx13 : Tx15 for @1310nm and @1550nm Tx13 : Rx13 for @1310nm Tx13 : Rx15 for @1310nm Tx15 : Rx13 for @1550nm Tx15 : Rx15 for @1550nm	dB	35 / 44 35 / 44 45 / 54 40 / 46 > 55 20 / 22 > 55 > 55 > 55 > 55 > 55 > 55
Return loss (RL)	dB	> 55
Operating temperature range	°C	from 0 to 40
Housing	-	LGX 3U/1
Weight	kg	0,3

MLS 60-L1-1A-2E 1310-1550

MLS 60-L1-1A-2E 1310-1550		
Working wavelength bands	nm	1290 - 1330 1530 - 1570
Fiber // connector type	μm	SM, 9/125 // E2000/APC
Number of optical ports	-	3
Front panel marking - line port - input/output ports	-	LINE IN13/OUT15, OUT13/IN15
Maximum/typical insertion loss between optical ports IN13/OUT15 : LINE for @1310nm IN15/OUT13 : LINE for @1550nm LINE : IN15/OUT13 for @1310nm LINE : IN13/OUT15 for @1550nm	dB	1,8 / 0,7 3,5 / 2,6 1,8 / 0,7 3,5 / 2,6
Minimum/typical isolation between ports LINE : IN13/OUT15 for @1310nm LINE : IN15/OUT13 for @1550nm IN15/OUT13 : LINE for @1310nm IN13/OUT15 : LINE for @1550nm IN13/OUT15 : IN15/OUT13 for @1550nm IN15/OUT13 : IN13/OUT15 for @1310nm	dB	30 / 46 20 / 23 30 / 46 20 / 23 > 55 > 55
Return loss (RL)	dB	> 55
Operating temperature range	°C	from 0 to 40
Housing	-	LGX 3U/1
Weight	kg	0,3

Circulators

MLS 70-C0-3SD-2E

MLS 70-C0-3SD-2E		
Fiber // connector type	μm	SM, 9/125 // E2000/APC
Number of devices in the unit	-	1
Number of opt. connectors	-	3
Center wavelength	nm	1310
Isolation	dB	> 40, typ. >50
Insertion loss (IL) (1290 – 1330 nm) *	dB	1,1
Directivity	dB	> 50
Polarisation dependent loss (PDL)	dB	< 0,15
Return loss (RL)	dB	> 50
Operating temperature range	°C	from 0 to 40
Temperature stability *	dB	< 0,2
Housing	-	LGX 3U/1 (drawing 7)
Weight	kg	0,3

MLS 70-C0-3DD-2E

MLS 70-C0-3SD-2E		
Fiber // connector type	μm	SM, 9/125 // E2000/APC
Number of devices in the unit	-	2
Number of opt. connectors	-	6
Center wavelength	nm	1310
Isolation	dB	> 40, typ. >50
Insertion loss (IL) (1290 – 1330 nm) *	dB	1,1
Directivity	dB	> 50
Polarisation dependent loss (PDL)	dB	< 0,15
Return loss (RL)	dB	> 50
Operating temperature range	°C	from 0 to 40
Temperature stability *	dB	< 0,2
Housing	-	LGX 3U/1 (drawing 7)
Weight	kg	0,3

* splices and connectors included

Splitters

MLS 70-S2-1A2-2E (1x2)

MLS 70-S2-1A2-2E		
Type of splitter	-	fusion
Fiber // connector type	μm	SM, 9/125 // E2000/APC
Number of optical ports	-	3 (1+2)
Working wavelength range	nm	1270÷1350 and 1510÷1590
Maximum/typical insertion loss (IL) *	dB	4,1 / 3,2
Directivity	dB	typ. 55
Polarisation dependent loss (PDL)	dB	< 0,15
Uniformity (typical)	dB	0,7
Return loss (RL)	dB	> 55
Operating temperature range	°C	from 0 to 40
Temperature stability *	dB	< 0,2
Housing	-	LGX 3U/1
Weight	kg	0,26

* splices and connectors included

MLS 70-S2-1A4-2E (1x4)

MLS 70-S2-1A4-2E		
Type of splitter	-	fusion
Fiber // connector type	μm	SM, 9/125 // E2000/APC
Number of optical ports	-	5 (1+4)
Working wavelength range	nm	1270÷1350 and 1510÷1590
Maximum/typical insertion loss (IL) *	dB	7,7 / 7,0
Directivity	dB	typ. 55
Polarisation dependent loss (PDL)	dB	< 0,15
Uniformity (typical)	dB	1,1
Return loss (RL)	dB	> 55
Operating temperature range	°C	from 0 to 40
Temperature stability *	dB	< 0,2
Housing	-	LGX 3U/1
Weight	kg	0,28

* splices and connectors included

MLS 70-S4-1A2-2E (1x2)

MLS 70-S2-1A2-2E		
Type of splitter	-	planar
Fiber // connector type	μm	SM, 9/125 // E2000/APC
Number of optical ports	-	3 (1+2)
Working wavelength range	nm	1260÷1360 and 1480÷1650
Maximum/typical insertion loss (IL) *	dB	4,4 / 3,9
Directivity	dB	> 55
Polarisation dependent loss (PDL)	dB	< 0,2
Uniformity (max)	dB	0,3
Return loss (RL)	dB	> 55
Operating temperature range	°C	from 0 to 40
Temperature stability *	dB	< 0,2
Housing	-	LGX 3U/1
Weight	kg	0,26

* splices and connectors included

MLS 70-S4-1A4-2E (1x4)

MLS 70-S2-1A4-2E		
Type of splitter	-	planar
Fiber // connector type	μm	SM, 9/125 // E2000/APC
Number of optical ports	-	5 (1+4)
Working wavelength range	nm	1260÷1360 and 1480÷1650
Maximum/typical insertion loss (IL) *	dB	7,8 / 7,2
Directivity	dB	> 55
Polarisation dependent loss (PDL)	dB	< 0,2
Uniformity (max)	dB	0,5
Return loss (RL)	dB	> 55
Operating temperature range	°C	from 0 to 40
Temperature stability *	dB	< 0,2
Housing	-	LGX 3U/1
Weight	kg	0,28

* splices and connectors included

MLS 70-S4-1A8-2E (1x8)

MLS 70-S2-1A8-2E		
Type of splitter	-	planar
Fiber // connector type	μm	SM, 9/125 // E2000/APC
Number of optical ports	-	9 (1+8)
Working wavelength range	nm	1260÷1360 and 1480÷1650
Maximum/typical insertion loss (IL) *	dB	11,3 / 10,4
Directivity	dB	> 55
Polarisation dependent loss (PDL)	dB	< 0,2
Uniformity (max)	dB	0,7
Return loss (RL)	dB	> 55
Operating temperature range	°C	from 0 to 40
Temperature stability *	dB	< 0,2
Housing	-	LGX 3U/2
Weight	kg	0,5

* splices and connectors included

LGX style chassis

MLS 80-2U-01

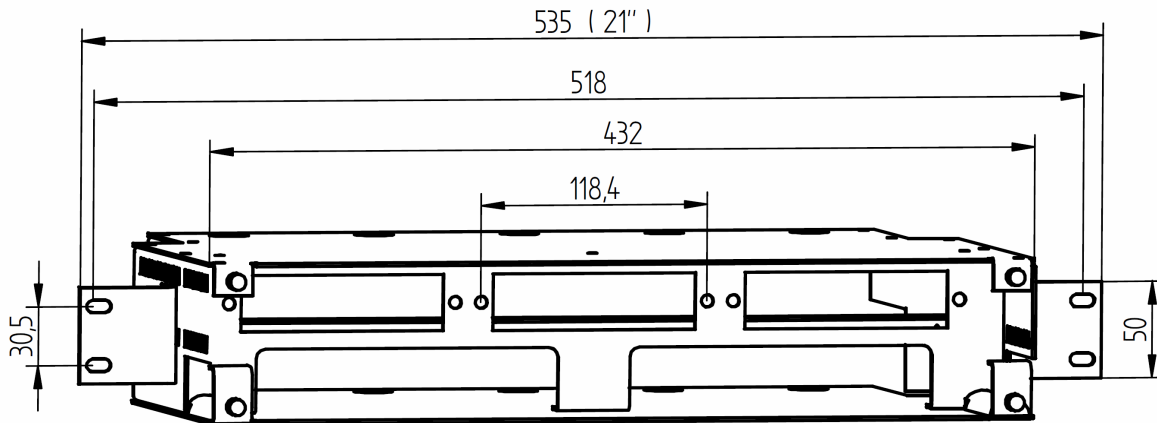

Drawing 1: 2U chassis with holders for 21" rail spacing, version for 3 boxes 1LGX / 3U

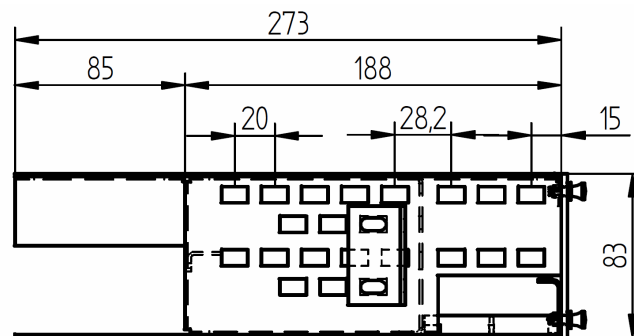

Drawing 2: 2U chassis side-view

MLS 80-2U-02

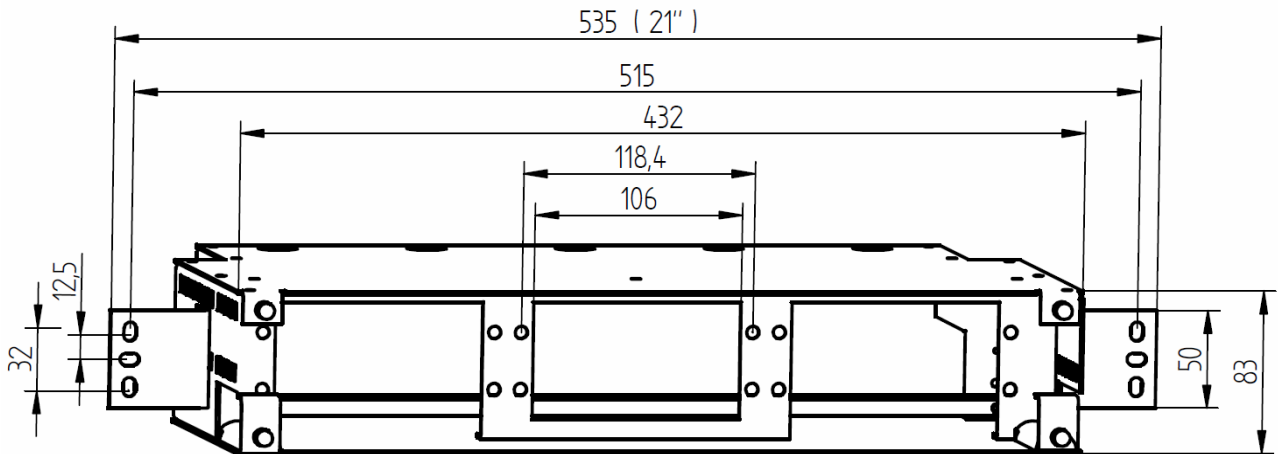

Drawing 3: 2U chassis with holders for 21" rail spacing, version for 3 boxes 2LGX / 3U

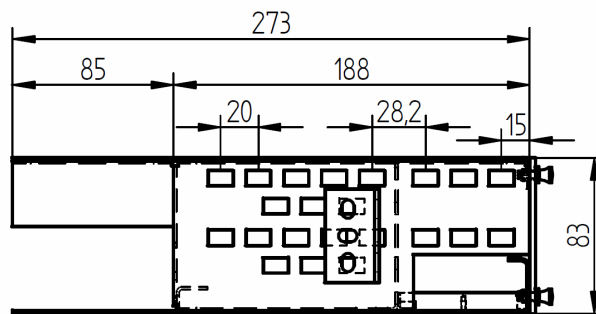

Drawing 4: 2U chassis side-view

MLS 80-4U-01

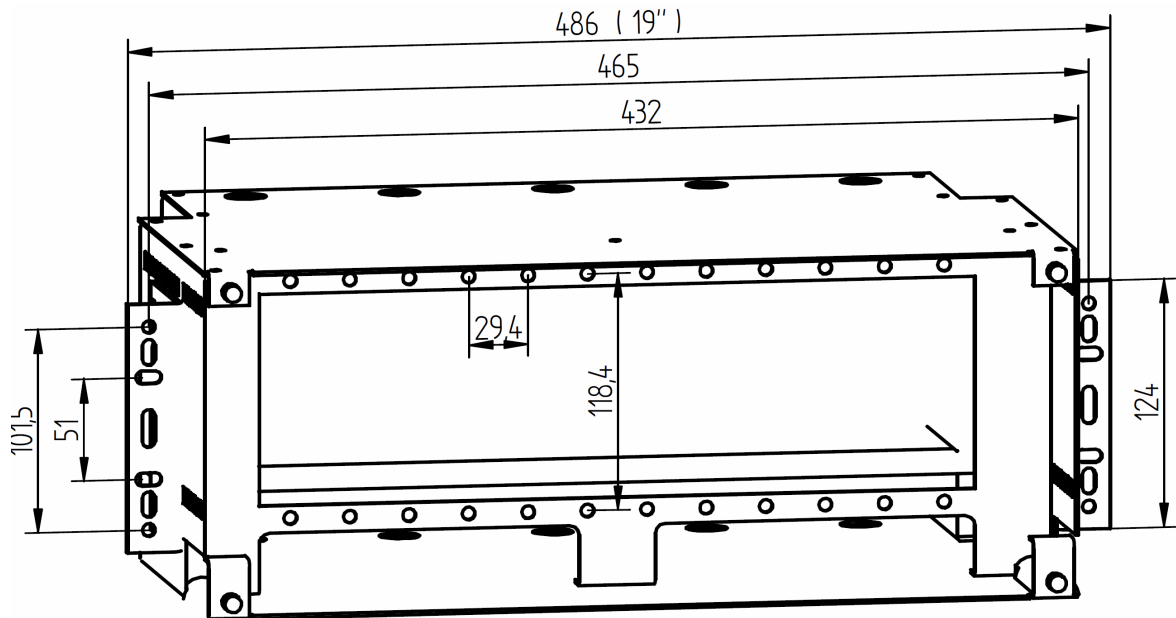

Drawing 5: 4U chassis with holders for 19" rail spacing.

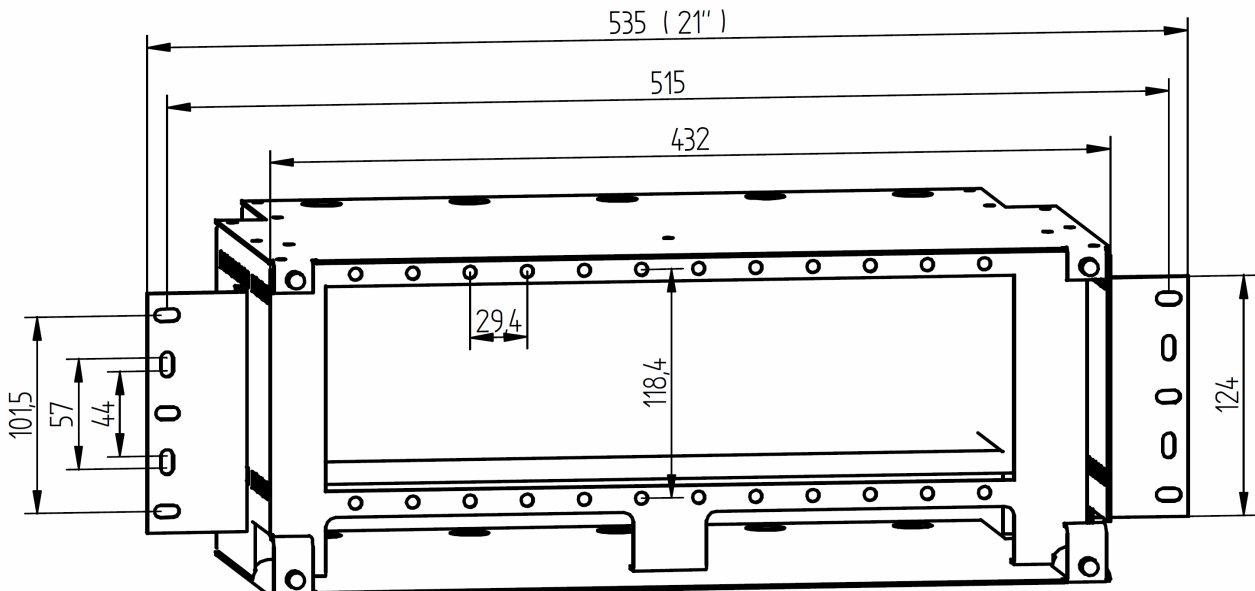

Drawing 6: 4U chassis with holders for 21" rail spacing.

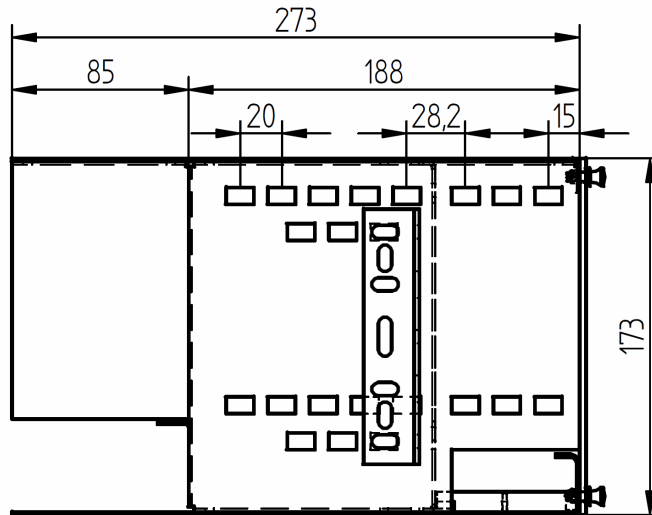

Drawing 7: 4U chassis side-view

MLS 80-3U-01

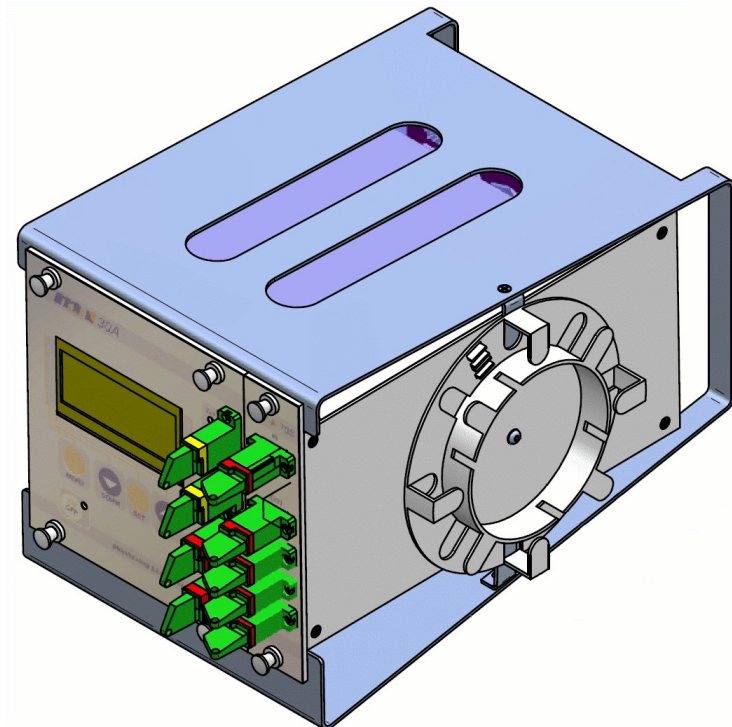

Drawing 8.: MLS 80-3U-01 in a set with MLS 30A and MLS 70

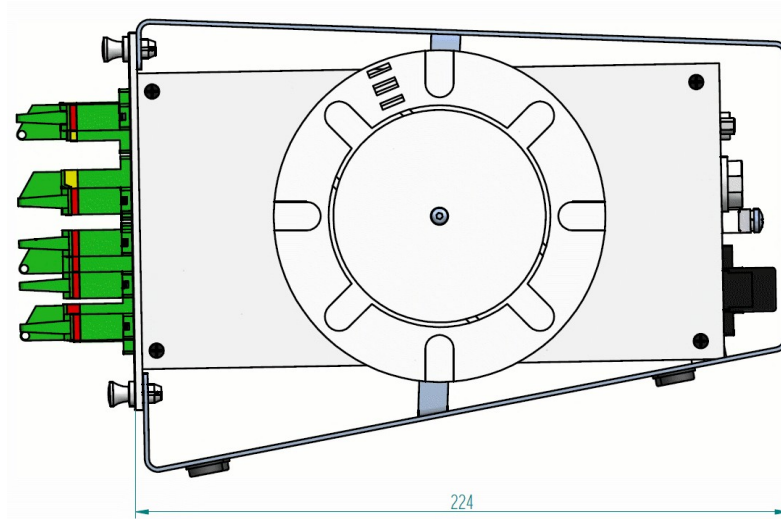

Drawing 9.: MLS 80-3U-01 – side view

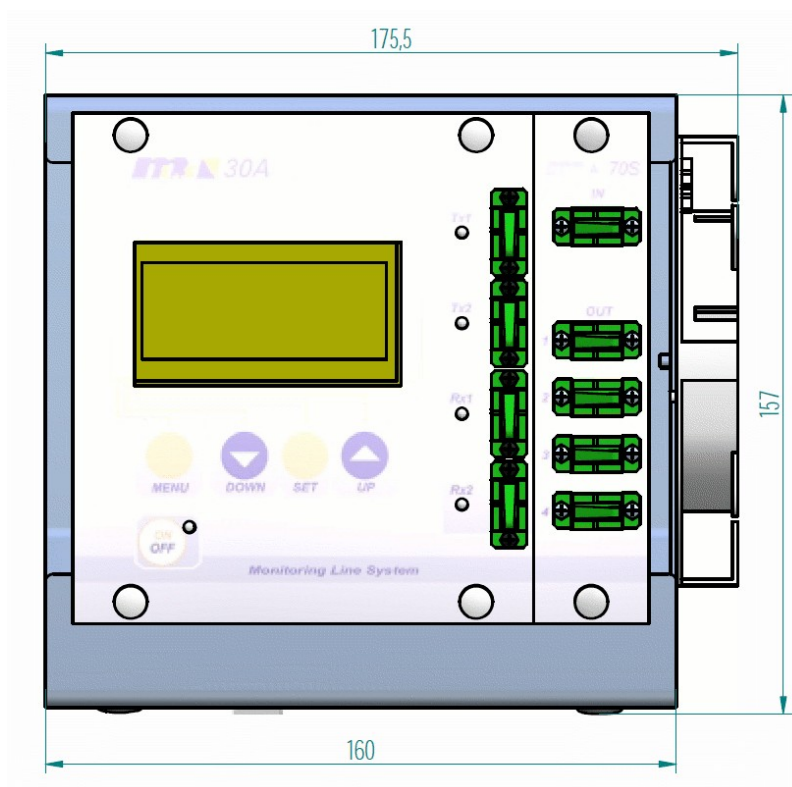

Drawing 10.: MLS 80-3U-01 – front view

MLS unit		MLS 80-2U-01	MLS 80-2U-02	MLS 80-4U-01	MLS 80-4U-01
Weight	kg	1,46	1,5	1,9	0,4

Note: Plexi-cover included.

LGX compatible boxes

Boxes 1LGX / 3U

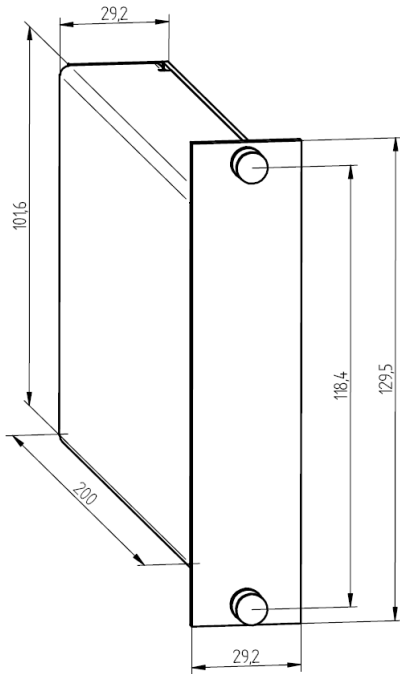

Drawing 11: Single-wide long module

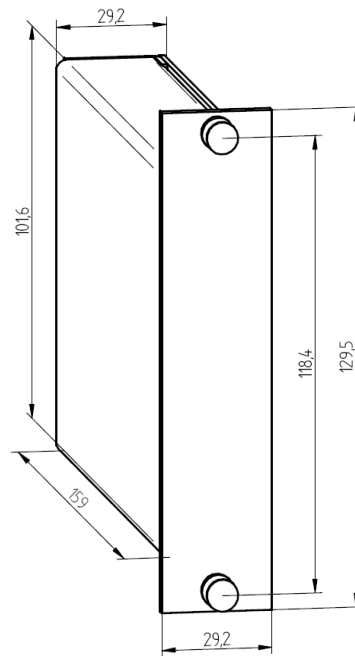

Drawing 12: Single-wide module

Box 2LGX / 3U

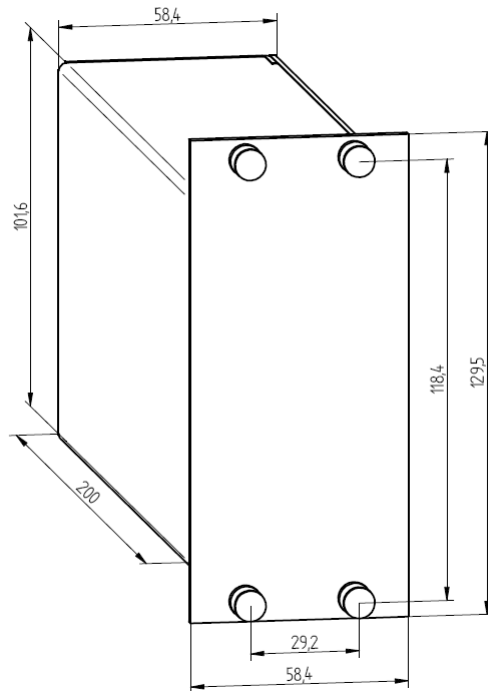

Drawing 13: Double-wide long module

Box 4LGX / 3U

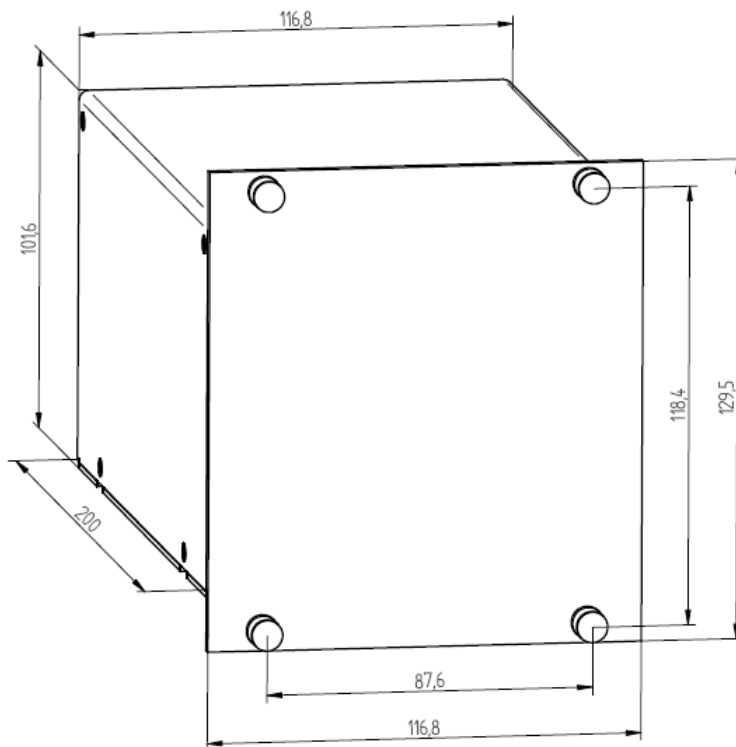

Drawing 14: Quadruple-wide long module

Optical switches

MLS 90-O Optical switches 1x2 and 1x4

Brief characteristics

- Latching optical switches 1x2 and 1x4 with fast response;
- Remote control via RS485 bus;
- Local control from the front panel (blockable);
- Long-term stability;
- Wavelength range from 1260 to 1650 nm;
- Communication, status and position indicated on the front panel;
- Optical switch position immune to power supply interruption;
- With the switches 1x2, the control by means of an external el. contact available;
- Power supply 48V DC;
- Housing: long 2LGX / 3U module.

(For parameters see next page.)

MLS90-P Optical switches 1x4 , 1x8

Brief characteristics

- Optical switches 1x4 and 1x8 with fast response;
- Remote control via RS485 bus;
- Local control from the front panel (blockable);
- Long-term stability;
- Wavelength range from 1260 to 1650 nm;
- Communication, status and position indicated on the front panel;
- Optical switch position immune to power supply interruption;
- With the switches 1x2, the control by means of an external el. contact available;
- Power supply 48V DC;
- Housing: long 2LGX / 3U module.

(For parameters see next two pages.)

MLS 90-O series - parameters

MLS unit		MLS 90-O1-D 1 x 2	MLS 90-O2-D 1 x 2	MLS 90-O1-D 1 x 4	MLS 90-O2-D 1 x 4
Number of optical channels	-	2	2	4	4
Number of optical ports	-	3	3	5	5
Band	nm	850/1300	1280 - 1340 1520 - 1625	850/1300	1280 - 1340 1520 - 1625
Fiber type	-	MM 50/125	SM 9/125	MM 50/125	SM 9/125
Insertion loss typical/ maximum (connectors included)	dB	0,9 / 1,2	0,9 / 1,3	1,5 / 2,1	1,5 / 2,3
Return loss	dB	-	< -45	-	< -45
PDL	dB	-	< 0,1	-	< 0,1
Crosstalk	dB	< -80			
Repeatability (for const. temperature)	dB	±0,03		±0,05	
Switching time *1	ms	< 10	< 5	< 10	< 5
Order time *2	ms	22			
Response *3	ms	< 42	< 37	< 42	< 37
Response to the ext. contact *4	ms	< 20	< 15	-	-
Lifetime (cycles)	-	> 10 ⁷			
Connector type	-	E2000/APC or SC/APC			
Stability (in whole temperature range)	dB	±0,2		±0,4	
Stability (in temp. band of ±3 °C)	dB	±0,1		±0,2	
Operating temperature range	°C	from 0 to 40			
Power supply voltage - nominal - range	V V	48 (DC) 18 - 72 (DC)			
Maximum consumption	W	1,5			
Typical consumption	W	1,2			
Housing	-	2LGX/3U			
Weight	kg	0,69		0,75	

*1 The time of optical power changes during the switching process.

*2 The time needed for continuous order transmitted via serial line RS485 at the rate of 9600 Bd.

*3 Complete time from the start of the order transmission to the end of transients at the optical side.

*4 Valid for the switches 1 x 2 only, when controlled by the external contact.

MLS 90-P series - parameters

MLS unit		MLS 90-P2-D 1 x 4	MLS 90-P2-D 1 x 8	MLS 90-P2-D 1 x12 (preliminary)	MLS 90-P2-D 1 x16 (preliminary)
Number of optical channels	-	4	8	12	16
Number of optical ports	-	5	9	13	17
Band	nm	1200 - 1650			
Fiber type	-	SM 9/125			
Insertion loss typical/ maximum (connectors included)	dB	1260-1360nm 0,6 / 1,2 1480-1600nm 0,8 / 1,2 1200-1650nm 1,0 / 1,8			
Return loss	dB	< - 65			
PDL	dB	< 0,1			
Crosstalk	dB	< -55			
Repeatability (for const. temperature)	dB	< 0,005			
Switching time *1	ms	< 2			
Order time *2	ms	22			
Response *3	ms	< 36			
Lifetime (cycles)	-	> 10 ⁸			
Connector type	-	E2000/APC or SC/APC			
Stability (in whole temperature range)	dB	±0,15			
Stability (in temp. band of ±3 °C)	dB	±0,05			
Operating temperature range	°C	from 0 to 40			
Power supply voltage - nominal - range	V V	48 (DC) 18 - 72 (DC)			
Maximum consumption	W	1,8			
Typical consumption	W	1,5			
Housing	-	2LGX/3U		4LGX/3U	
Weight	kg	0,85	0,9	1,4	1,5

*1 The time of optical power changes during the switching process.

*2 The time needed for continuous order transmitted via serial line RS485 at the rate of 9600 Bd.

*3 Complete time from the start of the order transmission to the end of transients at the optical side.

*4 Valid for the switches 1 x 2 only, when controlled by the external contact.

MLS 90-S Optical switches 1x24, 1x32 and 1x48

Brief characteristics

- Remote control via RS485 bus and/or RS232;
- Long-term stability;
- Wavelength range from 1200 to 1650 nm;
- Communication, status and position indicated on the front panel;
- Optional latch type optical switch;
- Power supply 48V DC;
- Housing: MLS80-2U-03 (2U chassis with holders for 19" and 21" rail spacing);

MLS unit		MLS 90-S2-2D 1x24	MLS 90-S2-2D 1x32	MLS 90-S2-2D 1x48
Number of optical channels	-	24	32	48
Number of optical ports	-	25	33	49
Band	nm	1200 - 1650		
Fiber type	-	SM 9/125		
Insertion loss (typical / maximum)	dB	0,8 / 1,5		
Return loss (typical / maximum)	dB	>60 / >55		
PDL	dB	< 0,1		
Crosstalk (typical / maximum)	dB	>80 / >70		
Repeatability (typical / maximum)	dB	±0,01 / ±0,03		
Switching time	ms	65 + 10 / channel		
Lifetime (cycles)	-	> 10 ⁷		
Connector type	-	E2000/APC or SC/APC		
Stability (in whole temperature range)	dB	±0,2		
Stability (in temp. band of ±3 °C)	dB	±0,05		
Operating temperature range	°C	from 0 to 40		
Power supply voltage - nominal - range	V V	48 (DC) 18 - 72 (DC)		
Maximum consumption	W	5		
Typical consumption	W	2		
Control interface	-	RS232 , RS485		
Weight (without holders)	kg	3,00	3,10	3,25
Housing	-	MLS 80-2U-03 (2U box derived from MLS 80-2U-02 chassis. See page 28.)		

MLS 90 Optical switches 1x12, 1x16, 1x64, 1x96 and 1x128 are in development.

Reflectometers

MLS 400 OTDR

Brief characteristics

- Reflectometers enable combination of transmitting and OTDR measurements resulting in really powerful monitor and fault detection system;
- OTDRs EXFO are preferably used in MLS;
- measurement process is controlled by Pentium equipped with 512 MB RAM;
- measuring ranges selectable;
- transparent screen with high resolution;
- simultaneous acquisition and data processing;

Measurement modules

- both MM and SM modules available;
- SM measurement modules offer the wave-lengths of 1310, 1410, 1490, 1550 and 1625 nm and dynamic range up to 45 dB.

OTDR units – parameters

MLS 400 (generally)		
Connectors	-	DIN
Operating temperature range	°C	0 ÷ 50
Storage temperature	°C	-40 ÷ 60
Power supply voltage AC, 50/60 Hz	V	100–240
Power supply voltage DC	V	12–24
Weight (battery included)	kg	7,5

MLS 400 – Type of the OTDR unit	Description		
	Fiber type	measurement wave-length	dynamic range
MLS 400-E2-34	SM	1550nm	34 dB
MLS 400-E2-37	SM	1550nm	37 dB
MLS 400-E2-40	SM	1550nm	40 dB
MLS 400-E2-43	SM	1550nm	43 dB
MLS 400-E3-35	SM	1625nm	35 dB
MLS 400-E3-38	SM	1625nm	38 dB
MLS 400-E3-41	SM	1625nm	41 dB
MLS 400-E23-4038	SM	1550/1625nm	40/38 dB
MLS 400-E23-4341	SM	1550/1625nm	43/41 dB

Type designations

MLS 30-Ax-rst-nb-mm Combined autonomous units

where:

MLS 30-A is type identification common to all variants

x - is the wavelength of the built-in laser, where

- x=1 - for the 1310 nm waveband
- x=2 - for the 1550 nm waveband
- x=3 - for the 1625 nm waveband
- x=4 - for the 1610 nm waveband

r - is number of lasers, where

- r=1 - for 1 laser

s - indicates the presence of a splitter, where

- s=N - splitter not applied
- s=S - splitter 50/50

t - is a number of photo detectors, where

- t=1 - for 1 PIN diode
- t=2 - for 2 PIN diodes

n - specifies the type of a power supply required, where

- n=D - 48V DC
- n=A - 230V AC
- n=N - 5V DC

b - specifies output voltage of the the built-in power supply

- b=1 - DC 5V
- b=5 - DC 48V and DC 5V

mm – The optional suffix of “MM” indicates multi-mode version of the device.

MLS 30-Tx-rs-n Transmitters

where:

MLS 30-T is type identification common to all variants

x - is the wavelength of the built-in laser, where

- x=1 - for the 1310 nm waveband
- x=2 - for the 1550 nm waveband
- x=3 - for the 1625 nm waveband
- x=4 - for the 1610 nm waveband

r - is number of lasers, where

- r=1 - for 1 laser
- r=4 - for 4 lasers

s - indicates the presence of a splitter, where

- s=N - splitter not applied
- s=S - splitter 50/50
- s=Q - splitter 25/25/25/25

n - specifies the type of a power supply required, where

- n=D - 48V DC

MLS 30-Tx-n Ch1-Ch2-Ch3-Ch4
Transmitters – alternative extended code

where:

MLS 30-T is type identification common to all variants

x - remains "x" as an identifier of the extended code

n - specifies the type of a power supply required, where
n=D - 48V DC

Ch1 - specifies LD of the optical channel Nr.1

Ch1 is always of 5 digit format **tdddd**

where: **t** - specifies the type of LD

t=D for DFB laser

t=F for FP laser

t=M for multi mode source LED

dddd - directly specifies the LD wavelength in nm

Ch2 - specifies the optical channel Nr.2

a) the light source **is not** shared with Ch1

A five digit string **tdddd** specifies the LD as described above.

b) the light source is shared with Ch1 by means of a splitter

A two digit string **pp** specifies the splitter.

pp – relative part of the total optical power of the last specified LD (in percent)

Ch3 and **Ch4** – are analogous to Ch2.

Examples:
MLS 30-Tx-D F1310-F1550-D1610-50

There are 4 channels in the module.

The first one utilizes FP laser 1310nm. The second one utilizes FP laser 1550nm.

The third and the fourth channels are supplied by DFB laser 1610nm. They are connected via a splitter and 50% of total LD optical power goes to the channel 4.

MLS 30-Tx-D F1310-25-25-25

There are 4 channels in the module.

All channels utilize one FP laser 1310nm and are connected via a splitter 25/25/25/25.

MLS 30-Tx-D D1550-10

There are 2 channels in the module.

Both channels utilize one DFB laser 1550nm and are connected via a splitter 90/10.

MLS 30-Rx-t-ny Receivers

where:

MLS 30-R is type identification common to all variants

x - is calibration wavelength, where

x=2 - for the 1550 nm waveband

x=3 - for the 1610 nm waveband

t - is a number of photo detectors, where

t=1 - for 1 PIN diode

t=2 - for 2 PIN diodes

t=3 - for 3 PIN diodes

t=4 - for 4 PIN diodes

n - specifies the type of a power supply required, where

n=D - 48V DC

n=S - 48V DC with signalling pins in power connector

y - specifies the type the detector coupling, where

y=1 - PIN diode with a PIGTAIL (contact of two opt. connectors in the E2000 adapter)

y=2 - built-in PIN diode in the E2000 adapter (no contact of the connector front face)

MLS 40-ab-n Power supply units

where:

MLS 40 is type identification common to all variants

a - specifies the box width

a=A - 1 LGX

a=B - 2 LGX

a=C - 3 LGX

a=D - 4 LGX

b - specifies output voltage of the the built-in power supply

b=1 - DC 5V

b=2 - DC 12V

b=4 - DC 48V

b=5 - DC 48V and DC 5V

b=6 - DC 48V and DC 12V

b=7 - DC 48V and DC 12V ans DC 5V

n - specifies the type of a power supply required, where

n=A - 230V AC / 50Hz

MLS 50-ab-n Communicators

where:

MLS 50 is type identification common to all variants**a** - is a variant of the communicator

- a=A - communicator for a remote control (only)
- a=B - autonomous communicator

b - specifies output voltage of the the built-in power supply, where

- b=0 - no power supply for other MLS modules
- b=1 - DC 5V
- b=4 - DC 48V
- b=5 - DC 48V / DC 5V

n - specifies the type of a power supply required, where

- n=A - AC 230V / 50Hz
- n=D - DC 48V
- n=N - DC 5V

MLS 60-ux-yz-op WDM units

where:

MLS 60 is type identification common to all variants**u**- specifies a number of WDM components built in the unit

- u=V - 1 WDM component
- u=W - 2 WDM components

x - specifies working and monitoring band, where

- x=1 - working band 1310 nm and monitoring band 1625 nm
- x=2 - working band 1310 nm and monitoring band 1550 nm
- x=3 - working band 1550 nm and monitoring band 1625 nm
- x=4 - working bands 1310 and 1550 nm and monitoring band 1625 nm
- x=5 - working band 850 nm and monitoring band 1310 nm (1300 nm)

y - specifies the internally looped waveband

- y=0 - no loop (no sense for u=V)
- y=1 - looped the 1310 nm channel
- y=2 - looped the 1550 nm channel
- y=3 - looped the 1625 nm channel
- y=4 - looped the 1310 and 1550 nm channels

z - specifies isolation between channels

- z=A - isolation = 15 dB
- z=B - isolation = 30 dB
- z=C - isolation = 45 dB

o - specifies the optical connector style

- o=1 - PC
- o=2 - APC

p- specifies the optical connector type

- p=E - connector E2000
- p=F - connector FC

MLS 60-Cx-yz-op CWDM and ADD&DROP units

where:

MLS 60-C is type identification common to all variants

x - is a number of channels, where

x=4 - for 4 channels CWDM

x=8 - for 8 channels CWDM

x - a letter (see the table below) specifies the central wavelength of ADD&DROP channel

y = a letter (see the table below) specifies the first channel central wavelength

z = a letter (see the table below) specifies the last channel central wavelength

o - is the optical connector style

o=1 - PC

o=2 - APC

p - is the optical connector type

p=E - connector E2000

p=F - connector FC

CWDM channel coding table

A = 1471nm	E = 1551nm	I = 1271nm	M = 1351nm	Q = 1431nm
B = 1491nm	F = 1571nm	J = 1291nm	N = 1371nm	R = 1451nm
C = 1511nm	G = 1591nm	K = 1311nm	O = 1391nm	
D = 1531nm	H = 1611nm	L = 1331nm	P = 1411nm	

MLS 60-Lx-yz-op Ch1-Ch2 directional WDM (line doublers)

where:

MLS 60-L is type identification common to all variants

x – directly specifies number of doublers in a box

y - specifies kind of connection

y=0 – two fibers connection (5 optical ports)

y=1 – single fiber connection (3 optical ports)

z - specifies isolation between channels

z=A - isolation = 15 dB

z=B - isolation = 30 dB

z=C - isolation = 45 dB

o - is the optical connector style

o=1 - PC

o=2 - APC

p - is the optical connector type

p=E - connector E2000

p=F - connector FC

Ch1 - directly specifies wavelength of the optimized channel (the channel for lower IL), in nm

Ch2 - directly specifies wavelength of the second channel in nm

MLS 70-Sr-stu-op Splitter units

where:

MLS 70-S is type identification common to all variants

r - is working waveband, where

- r=0 - for the 1310 nm waveband (fusion)
- r=1 - for the 1550 nm waveband (fusion)
- r=2 - for the 1310nm and 1550nm wavebands (fusion)
- r=4 - for the waveband 1200nm to 1650 nm waveband
- r=8 - for the waveband 850nm

s – directly specifies number of splitter input ports (i.e. number of built-in splitter devices)

t - is power ratio at the splitter output ports, where

- t=A - for symmetrical or uniform power division (50/50, 25/25/25/25, ...)
- t=B - for 40/60ratio
- t=C - for 30/70 ratio
- t=D - for 20/80 ratio
- t=E - for 10/90ratio
- t=F - for 5/95 ratio
- t=G - for 1/99 ratio

u - is a number of splitter output ports, where

- u=1 - for 1 output ports
- u=2 - for 2 output ports
- u=4 - for 4 output ports
- u=8 - for 8 output ports
- u=16 - for 16 output ports
- u=32 - for 32 output ports
- u=64 - for 64 output ports

o - is the optical connector style

- o=1 - PC
- o=2 - APC

p - is the optical connector type

- p=E - connector E2000
- p=F - connector FC
- p=S - connector SC

MLS 70-Sr-stu-op rtu-rtu-rtu...
Splitter units – extended code for multiple units

where:

MLS 70-S is type identification common to all variants

r – working waveband, where

letter “x” indicates multiple unit, with each splitter specified separately in the further part of the code where

- r=0 - for the 1310 nm waveband (fusion)
- r=1 - for the 1550 nm waveband (fusion)
- r=2 - for the 1310nm and 1550nm wavebands (fusion)
- r=4 - for the waveband 1200nm to 1650 nm waveband
- r=8 - for the waveband 850nm

s – directly specifies number of splitter input ports (i.e. number of built-in splitter devices)

t - is power ratio at the splitter output ports, where

letter “x” indicates multiple unit, with each splitter specified separately in the further part of the code where

- t=A - for symmetrical or uniform power division (50/50, 25/25/25/25, ...)
- t=B - for 40/60ratio
- t=C - for 30/70 ratio
- t=D - for 20/80 ratio
- t=E - for 10/90ratio
- t=F - for 5/95 ratio
- t=G - for 1/99 ratio

u – directly specifies the sum of splitter output ports

o - is the optical connector style

- o=1 - PC
- o=2 - APC

p - is the optical connector type

- p=E - connector E2000
- p=F - connector FC
- p=S - connector SC

rtu – specifies each built-in splitter as described above for the letters **r**, **t** and **u**

Example:

MLS 70-Sx-2x4-2E 2A2-2A2

Specifies the splitter unit with two splitters 1x2 built-in. Both splitters works in 1310 and 1550nm band, have symmetrical power ratio for two outputs, i.e. 50/50.

MLS 70-Cr-stu-op Circulators

where:

MLS 70-C is type identification common to all variants**r** - is working waveband, where

r=0 - for the 1310 nm waveband

r=1 - for the 1550 nm waveband

s - is a number of circulator ports

s=3 - for 3 ports

t - specifies the type of circulation, where

t=S - single (one element in the unit)

t=D - double

u - is isolation, where

u=A - for isolation = 15 dB

u=B - for isolation = 30 dB

u=C - for isolation = 45 dB

u=D - for isolation = 40 dB

u=E - for isolation = 50 dB

o - is the optical connector style

o=1 - PC

o=2 - APC

p - is the optical connector type

p=E - connector E2000

p=F - connector FC

p=S - connector SC

MLS 80-pU-xy LGX Style Chassis

where

MLS 80 is type identification common to all variants**p** - specifies the high of the chassis, where U=4,45cm and

p=2 - for high = 2U

p=3 - for high = 3U

p=4 - for high = 4U

xy - is an identifier of the version according to the design drawings

MLS 90-pq-mn a x b oc ddd/eee **Optical switches**

where:

MLS 90- is type identification reserved to optical switches

p - specifies a category, where

- p= O - for optical O-series switches
- p= P - for optical P-series switches
- p= S - for optical S-series switches

q - specifies a fiber type of built-in device, where

- q=1 – for MM
- q=2 – for SM

m - specifies the housing, where

- a=A - 1 LGX
- a=B - 2 LGX
- a=C - 3 LGX
- a=D - 4 LGX
- a=E - 5 LGX
- a=F - 6 LGX
- a=G - 7 LGX
- a=H - 8 LGX
- a=I - 9 LGX
- a=J - 10 LGX
- a=K - 11 LGX
- a=L - 12 LGX
- a=1 – 1U rack 19/21"
- a=2 – 2U rack 19/21"
- a=3 – 3U rack 19/21"
- a=4 – 4U rack 19/21"

n - specifies the type of a power supply required, where

- n=D - DC 48V
- n=N - DC 5V

a - directly specifies number of optical inputs

b - directly specifies number of optical outputs

o - is the optical connector style

- o=1 - PC
- o=2 - APC

c – optionally directly specifies type of optical connectors (default type is E2000)

- c = E - E2000
- c = F - FC
- c = S - SC

ddd/eee – optionally directly specifies the voltage level and wattage of a built-in subsidiary power supply output

ECCN designation for MLS

The Export Control Classification Number (ECCN) is issued by the Bureau of Industry and Security (BIS) for shipments that require an export license.

MLS category ECCN designation: **5B991** (Telecommunications test equipment)