

S326 Precision Cleaver Operating Instructions

- Please read entire manual prior to usage.
- This manual must be kept with the S326 Precision Cleaver.

Safety Instructions

This manual contains the complete operating and basic maintenance instructions for the S326 Precision Cleaver. Please review this manual carefully before using the S326 Precision Cleaver.

The following safety instructions must be followed whenever this product is operated, serviced, or repaired. Failure to comply with any of these instructions or with any precaution or warning contained in this manual is in direct violation of the standards of the design, the manufacturer, and the intended use of the instrument. FURUKAWA ELECTRIC CO., LTD. assumes no liability for the customer's failure to comply with these requirements.

Safety Instructions



CAUTION

Failure to comply with any of the instructions, which are indicated by this symbol, may cause serious injury or damage to the machine.



ATTENTION

Failure to comply with any of the instructions, which are indicated by this symbol, may cause the device to function improperly and degrade the performance.

Please contact FURUKAWA ELECTRIC CO., LTD. with any questions relating to the description of this manual.

In no case will FURUKAWA ELECTRIC CO., LTD. be liable to the buyer, for any consequential or indirect damage which is caused by product failure, malfunction, or any other problem.



CAUTION

- Avoid soaking the S326 with water. Doing so may cause malfunction.
- Do not drop, throw, and handle it roughly. Doing so may cause machine's malfunction.
- Do not use in a humid, dirty, or unstable site. Doing so may cause malfunction.
- Please be cautious when disposing of fibers from the fiber waste bin. Scattered fibers may cause injury.
- The fiber waste bin for loose fiber must be installed into the S326 during operation, otherwise there is danger for loose fiber to scatter.



ATTENTION

- Use an appropriate tool when loosening or tightening the set screw to fix the single fiber adapter to the unit and gently tighten the screw.
- Strip the fiber so that 14 to 25mm is exposed passed your aimed cleave length. This will allow the automatic fiber waste disposal feature to work properly. For instance :
In case of 16mm cleave length, remove the coating more than 30mm(=16+14), and less than 41mm(=16+25).
- Please clean the fiber with alcohol after stripping the coating material before setting it on to S326.
- Do not use Organic solvent (e.g. Acetone) to clean the rubber pads.

1. Components

Part Name	Part No.	S326A	S326B	S326S80
Main body	S326A-01	1	-	-
	S326B-01	-	1	-
	S326S80-01	-	-	1
Single fiber adaptor	S326X-11	1	1	1
Standard waste bin	S326X-12	2 (1 Reserve)	-	2 (1 Reserve)
Large waste bin	S326X-13	1	-	1
Semi Hard case	S326X-14	1	-	1
Soft case	S326X-15	-	1	-
Hexagonal wrench	S326X-16	1	1	1
Operating Instructions	FTS-B423	1	1	1

2. External Description

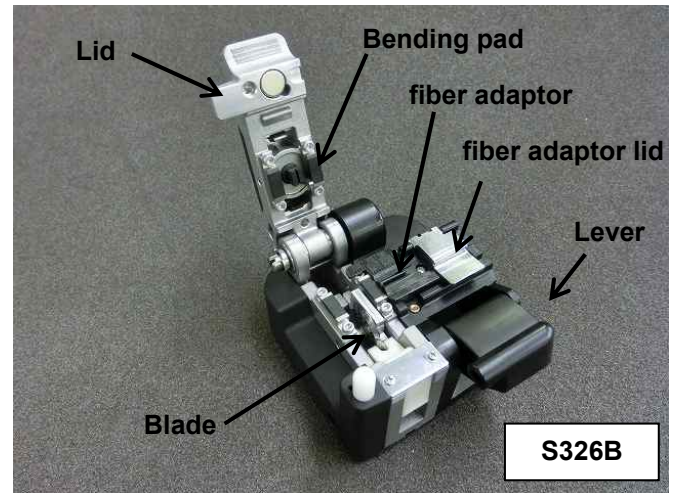
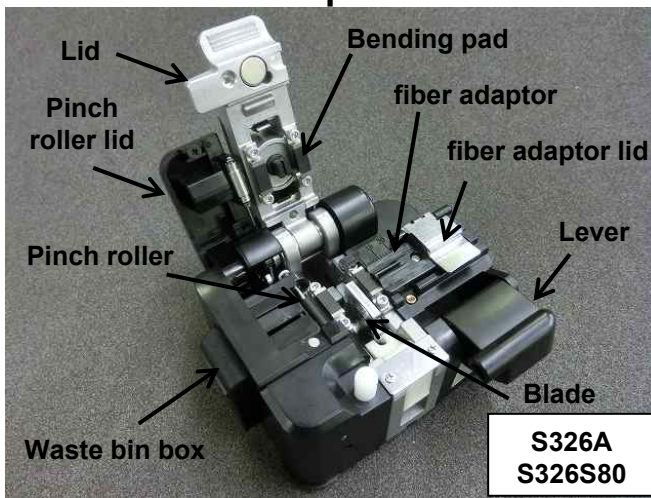

3. Applicable fiber type

Type	Cleave length	Used holder or adaptor
Single fiber Coating diameter 0.25 or 0.9mm	5 to 20mm	Supplied single fiber adaptor, S326X-11
Ribbon fiber 0.25mm pitch 2 to 12 fiber	10mm	Optional ribbon fiber holder

S326S80 is a cutting instrument cleaver designed only for single fiber whose optical fiber diameter is $80\mu\text{m}$.

Please use S326A or S326B for regular $125\mu\text{m}$ single or ribbon fiber cleaving task.

4. Operating instructions

4.1. Cleaving fiber

- 1) Open both main body and fiber adaptor lids. Place a prepared fiber (stripped and cleaned) across cleaving area with fiber end inserted into the waste bin. Ensure that the stripped fiber is long enough to reach the pinch roller.

Put fiber to proper v-groove, depending on desired cleaving length.

In the case of ribbon fiber cleaving, please use the ribbon fiber holder (Optional parts).

When using ribbon fiber, check that the fibers are aligned flatly and no fibers overlap with each other.

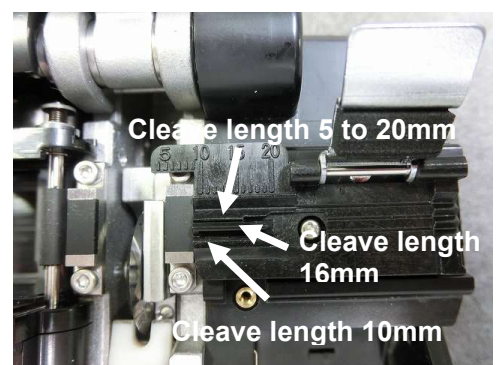

- 2) Close both main body and fiber adaptor lids and push the lid release lever until it stops. By pushing it completely, the blade will slide to cleave the fiber and send the loose fiber to the waste bin automatically (※1), and the lid will be automatically opened.

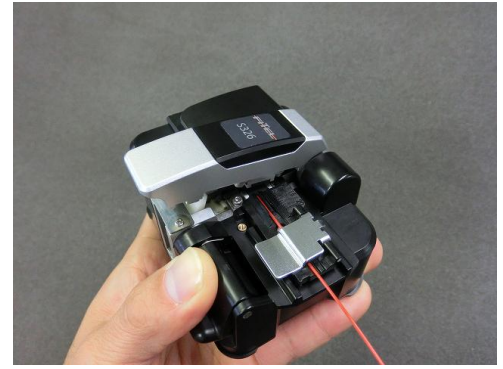

💡 Tip : Slide the sliding blade slowly to prolong the blade life.

⚠️ ATTENTION : During cleaving operation, please do not touch " Lid " and " Pinch roller lid ".

(※1) S326B does not have pinch roller and waste bin box.

- 3) Open both main body and fiber adaptor lids and remove the fiber from the unit.

4.2. Disposing of waste fiber

Dispose of waste fiber as follows after completion of work and before transporting the unit.

- 1) Grab the sides of the waste bin box with fingers and pull it out.
- 2) Grasp the left and right upper corners of waste bin with fingers and open the lid while squeezing lid lightly. Turn waste bin box upside down and dispose of the waste fiber into a designated trash can.



Do not put finger inside of waste bin because pieces of the optical fiber sometimes will remain in waste box after emptying it.

Put back waste bin box to original position after disposing the waste fiber.

⚠️ ATTENTION : When inserting waste bin box into main body, press waste box until click is heard.

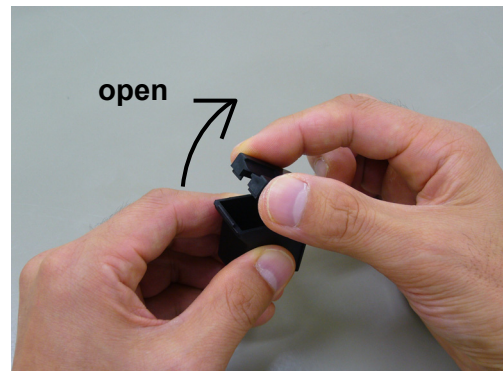

5. Maintenance and Rotation of blade

The blade has 24 positions printed on the side of the blade (i.e. "0·2·...·22·"). Each position can be used to 2,000 times. However, cleaving amount may be decreased with dust or oil contamination. When cleaving quality degrades, clean the top of blade and upper and lower bending pad with a cotton swab soaked with ethyl alcohol. If this does not help, that means it is time to rotate the blade(see below).

⚠️ ATTENTION : Do not use Organic solvent on rubber (e.g. Acetone).

⚠️ ATTENTION : Please note 2,000 cleaves per position is not guaranteed. The number of cleaving changes depending on the situation and environment (e.g. dust and oil.)

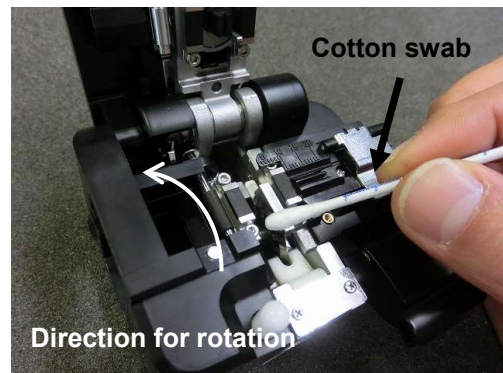

If operation above does not improve the cleave quality, the blade needs to be rotated. Follow the procedures below to rotate the blade.

1) Remove the waste bin from the main body. Loosen the blade set screw using hexagonal wrench.

2) Use a cotton swab, etc. to rotate the blade, so that the number shown at the top of the blade increase by one step. (Counter clock wise) The blade is positioned at "0" by default when manufactured in factory. The next position is "·" right after "0".

⚠ATTENTION : Do not touch the blade directly. It is very sharp and could cause injury.

3) Tighten the blade set screw again.

After all 24 positions are used and exhausted, the blade must be replaced by new one at customer's expense. Contact local service center for replacing blade service. S326A and S326S80 has an automatic waste fiber disposal function. To keep it operating properly, clean the pinch roller with cotton swab soaked in alcohol after each use. After repeated use, abrasion may form on the rubber of the pinch roller. However, the pinch roller keeps the function of collecting optical fiber, as long as the depth of a groove is smaller than the diameter of the fiber. When the function cannot work, even if after cleaning the pinch roller with alcohol, contact local service to replace the pinch roller with a new one at customer's expense. (※1) .

(※1) S326B does not have pinch roller and waste bin box.

6. Operating with ribbon fiber holder

Please remove single fiber adaptor (S326X-11) from the main body when you use the ribbon fiber holder (Optional parts). The fiber length from the holder edge to the cleaved fiber tip is 13mm.

7. Contacts



Service Department:

CS2 Group

Access Network Department, FITEL Products Division

Furukawa Electric Co., Ltd.

6, Yawata-Kaigandori, Ichihara, Chiba 290-8555 JAPAN

TEL:+81-436-42-1671 FAX : +81-436-42-1786

Sales Department:

Global Sales & Marketing

Furukawa Electric Co., Ltd.

2-3, Marunouchi 2Chome, Chiyoda-ku, Tokyo 100-8322 JAPAN

TEL : +81-3-3286-32 FAX : +81-3-3286-3978

